

PARTS LIST

Description	Qty.
Lightbar Assembly, N922 or N922E	1
Connectors, Scotchlok	6

PREPARATION

1. Remove Seat (10mm Wrench and 12mm Socket), set aside.
2. Remove Fuel Tank (12mm Socket & 8mm Socket), set aside.
3. Disconnect Turnsignal wires from inside the white box under fuel tank.
4. Remove Turnsignals, (8mm Socket), set aside, they will not be reused.
5. Remove Headlight from the Headlight Shell (Screwdriver).
6. Remove the screws holding the Headlight Shell to the Lower triple clamp (12mm Socket with Ratchet & 12mm Wrench).

INSTALLATION

NOTE: An assistant will make steps 1 (A through B) easier.

1. Mount the Light Bar Assembly:
 - A. Place the Light Bar assembly so the center mount bracket is between the lower Triple Clamp and the mounting bracket for the Headlight Shell.
 - B. Replace the Headlight Shell mounting screws and nuts, do not tighten at this time.
2. Wire the Light Bar assembly:

NOTE: check vertical aim of the lamps. They should aim approximately 5° downward. If adjustment is required see "Adjustment" page 2 of this instruction otherwise proceed with wiring step 2.

- A. Route Turnsignal & Running Light wires to white box under fuel tank.
- B. Route Spotlight wires into Headlight Shell.
- C. Attach wires as recommended in the following list. Do one at a time and check for correct operation. You may need to change wire connections to get the correct operation. (Connectors and Pliers).

	<u>Light Bar</u>	<u>Motorcycle</u>
Turnsignal, Left	Short Red	= Orange
Turnsignal, Right	Short Red	= Blue
Running Light, Left	Short Black	= Orange/White
Running Light, Right	Short Black	= Blue/White
Passing Lamps	Long Blue	= White (lo beam)
Ground		= Green

3. Reinstall the headlight and rim.
 - A. Check operation of all lights.
 - B. Reinstall wire box cover, fuel tank, seat, and lower Triple Clamp cover.

NOTE: Grounding is through the fork and frame.

NOTE: Check local regulations for proper passing lamp operation. Some states require passing lamps be lit only with hi-beam.



Screwdriver, #2 Phillips
 Socket, 12, 10 and mm, and Ratchet Wrench
 Extension, 6" (for 8mm Socket)
 Wrenches, 12mm and 10mm
 Pliers, Slip Joint, Hex Key 5mm
 Service Manual may be helpful in installation

NOTE: The service manual may be helpful in the installation.

NOTE: right and left on the motorcycle are determined from the rider's position.

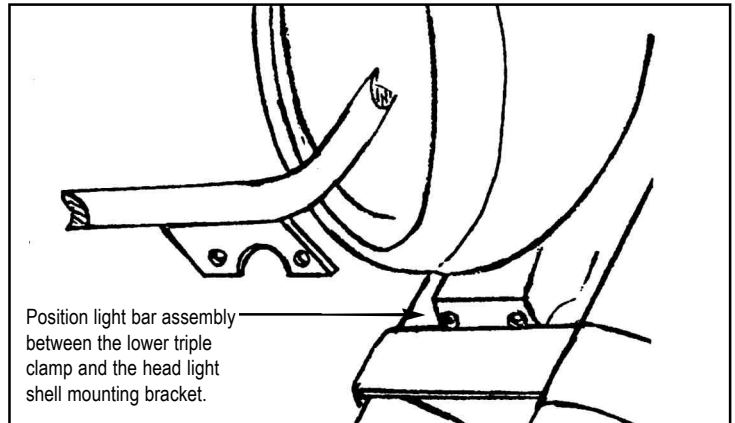

Note, Light Bar Wiring Helpful Hints:

The **long Blue** wire is the main power wire for the spotlights on the light bar. Connect that to the main power source from the headlight. Either the High Beam wire or the Low Beam wire. The choice is your preference. Turn on bike and Check.

The two short **RED** wires are for the turn signals. One **RED** wire for the Left side turn signal and one for the Right side turn signal. Turn on bike and check.

The two short **BLACK** wires are for the running lights. One **BLACK** wire for the Left side running light and one for the Right side running light. Turn on bike and check.

The Light Bar attached to the front fork of the motorcycle serves as the ground in most cases. A precautionary step to insure proper grounding is to take one of the Green Ground wires from the existing turn signals and ground that between the Light Bar Mount and the Triple Tree Bracket.

Always start by doing one side at a time. Preferably the right side or high side of the bike first.

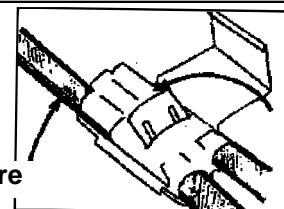

Through Wire

Wire From Light Bar Insert To Stop.

! WARNING

After wiring the light bar check for clearance. Make sure the wires can not get pinched when the fork is turned to a full fork lock left and right.

Check all lights for proper operation.

Check the tightness of all fasteners that have been involved in this installation.

MAINTENANCE

The high quality chrome finish of your National Cycle light bar can be maintained with any quality chrome cleaner and /or polish.

REPLACEMENT PARTS and ACCESSORIES

Order parts through your local dealer or contact National Cycle.

Description	N922 Part No.	N922E Part No.
Light Head Assembly	90-910501-000	90-910501-000
Lamp Assembly E13/DOT Reflector, Lens and Bulb	90-901011-000	90-901011-000
Turn Signal Assembly	90-930921-000	90-930921-000
Turn Signal Lens	90-930213-000	90-930213-000

Turn Signal Bulb Only: Bulb 1157 Available at Most Auto Parts Stores.

Light Bar Accessories

Chrome Visor	N9005
Alternate Thumb Switch	N9001

ADJUSTMENT

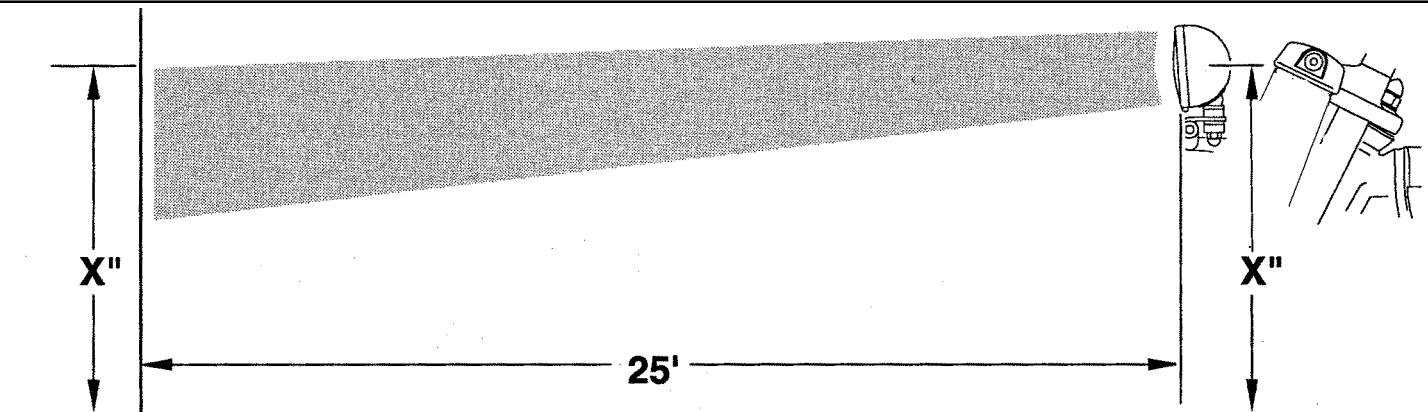

1. HORIZONTAL AIM

A. To adjust the Spotlights or Turnsignals right or left gently rotate the lamp into the correct position. In the event that the lamps become loose, refer to the procedure for vertical adjustment.

2. VERTICAL AIM

- Disconnect wire connections inside the Headlight Shell.
- Pull the wires out of the Light Bar tube.
- Turn the Turn signal to provide access to the mounting screws.
- Unscrew the Turn signal mounting screws and remove the Turnsignal (Hex Key).
- Push the Spotlight wire up into the Spotlight Shell.
- Loosen the nut on the Spotlight stud (Deep Socket).
- Now, adjust the Spotlight. Reconnect the spotlight wire and illuminate to verify its projection.
- Push wire into the Spotlight Shell.
- Firmly retighten the nut on the Spotlight stud.
- Pull the wire out of the Spotlight Shell.
- Reassemble in reverse order of disassembly.
- Adjust the Spotlights and Turn signals horizontally by rotating into position.
- Verify operation of the lights.

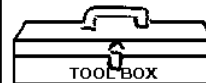

To adjust vertical aim you will need these additional tools: Hex Key, 5/32" or 4mm Deep Socket and Socket, 9/16" (14mm) or a 9/16" Slotted Socket.

NOTE: As a substitute for the deep socket you may use a slotted socket such as Snap On Brand part number FRX181 used in the auto trade as an OXY Sensor Socket. This eliminates the need to disconnect and move the wires.

Installing optional N9005 Light Head Visor.

- Loosen the rim of the light head assembly. (Phillips Screw Driver).
- Slip taps of Visor under rim. Item E.
- Shape Visor / Visor Tabs to conform to contours of light head assembly.
- Retighten rim.

