

HONDA

INSTALLATION INSTRUCTIONS

Accessory	Application	Publication No.
ACCESSORY SOCKET P/N 08U70-MGC-JB0	CB1100CA/NA	MII 16394
		Issue Date
		August 2017

Honda Dealer: Please give a copy of these instructions to your customer.

PARTS LIST

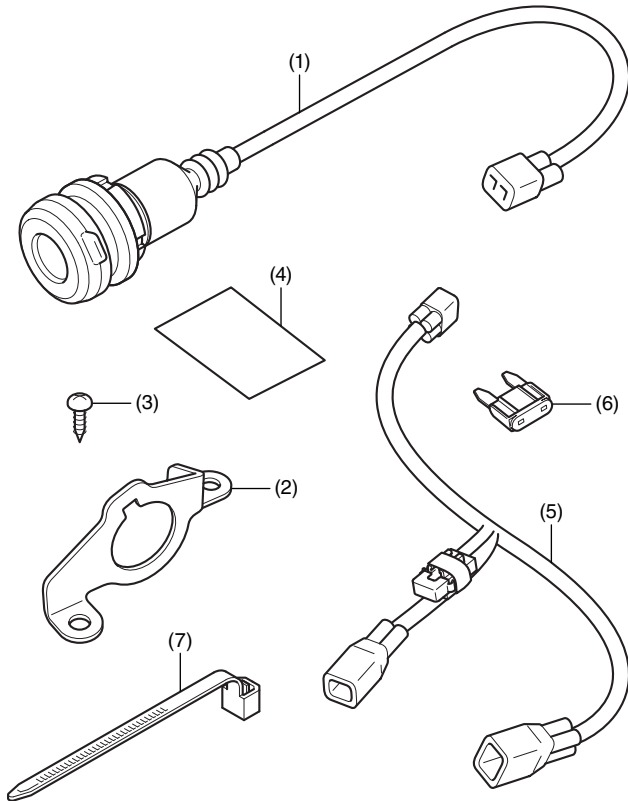

No.	Description	Qty
(1)	Accessory socket	1
(2)	Accessory socket stay	1
(3)	4 mm screw	2
(4)	URL paper	1
(5)	Accessory socket sub harness	1
(6)	Spare 3A mini fuse	1
(7)	Wire tie	1

TOOLS REQUIRED

Phillips screwdriver
Side cutters
Torque wrench

TORQUE CHART

Tighten all screws, bolts, and nuts to their specified torque values. Refer to the Service Manual for the torque values of the removed parts.

Item	N·m	kgf·m	lbf·ft
4 mm screw	1	0.1	0.7

INSTALLATION

▲ CAUTION

- To prevent burns, allow the engine and exhaust system to cool before installing the accessory.

NOTE:

- Disconnect the negative (-) cable from the battery before installing this accessory.
- The clock setting will be erased when you disconnect the battery. Reset the clock after reconnecting the battery.
- A spare 3A mini fuse is included, make sure to give it to the customer.
- Reinstall the removed parts on the motorcycle and make sure that the wires and harnesses are not pinched.
- Trim the excess ends off the wire ties after attaching them to the wire harnesses. Do not allow the cut part of the wire tie to interfere with another harness or brake hose.

- Remove the seat, tool bag, and left side cover as shown.

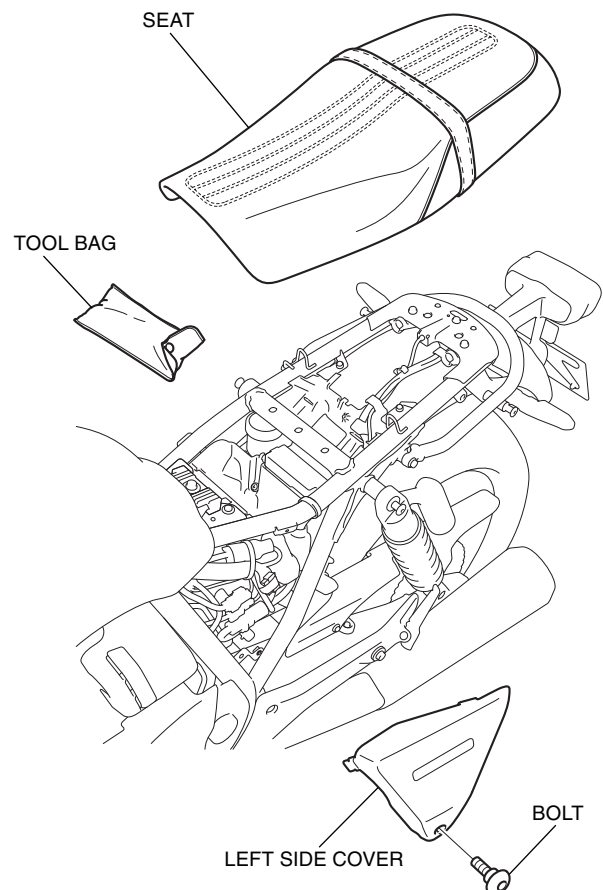

- Remove the battery cover as shown, and disconnect the negative (-) battery cable.

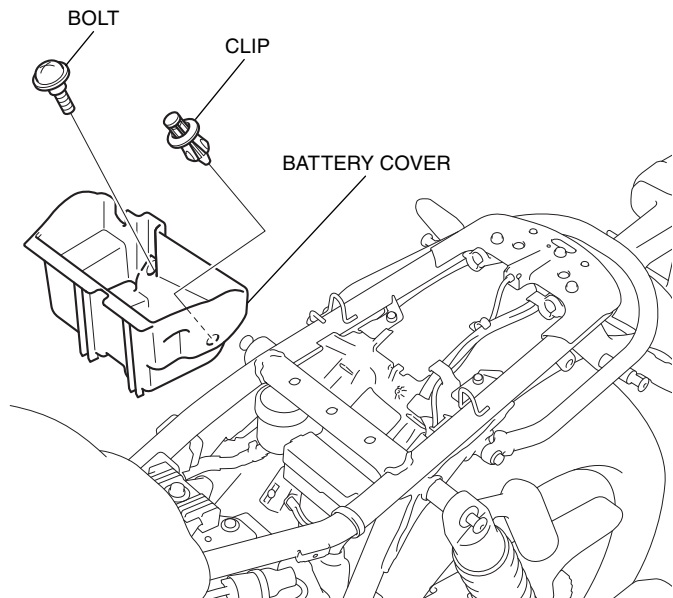

- Move the fuse box as shown.
<Left side>

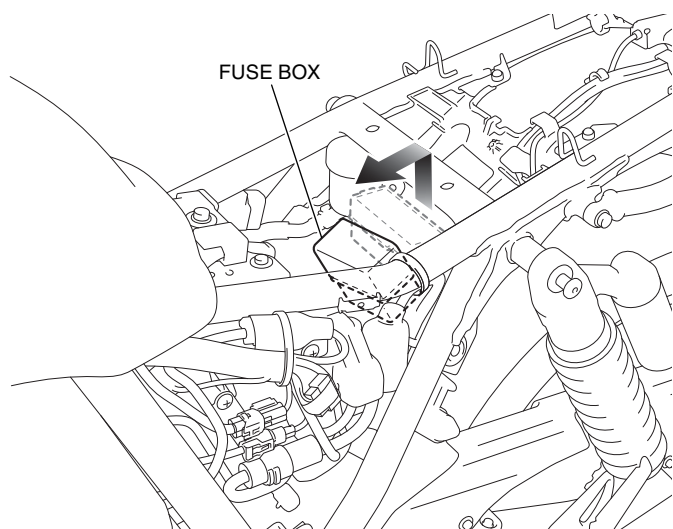

- Move the cover as shown.

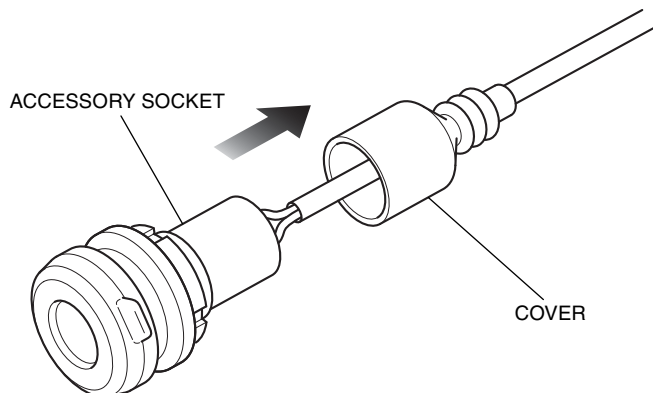

- Remove the nut as shown.

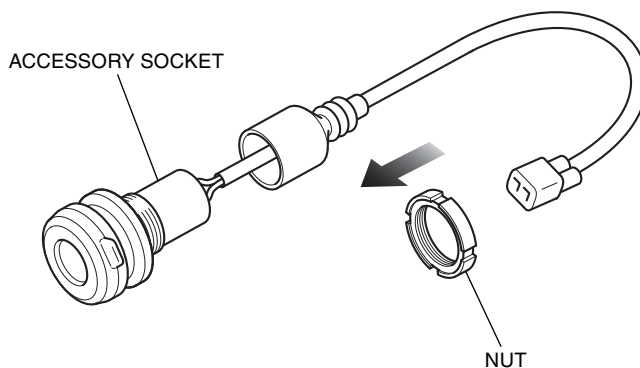

- Assemble the accessory socket as shown.

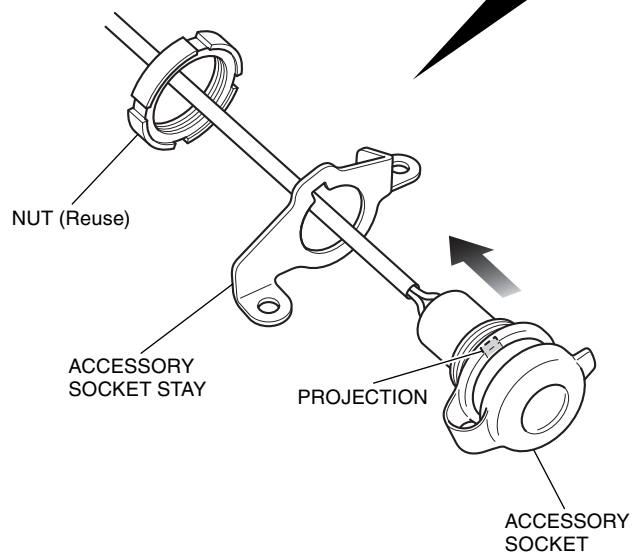
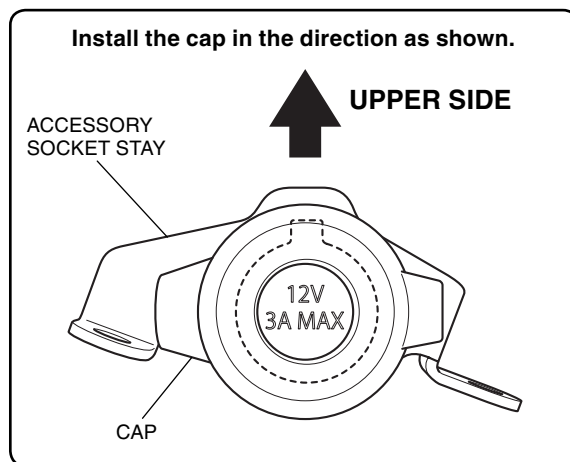

7. Install the cover as shown.

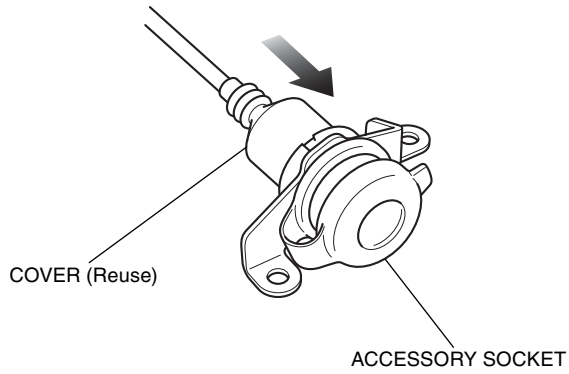

8. Install the assembled accessory socket as shown.

<Right side>

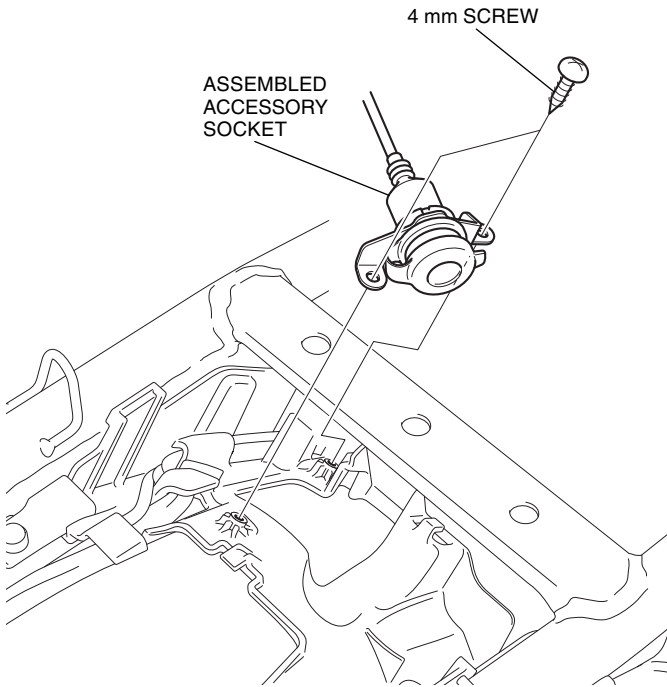

9. Route the accessory socket harness as shown.

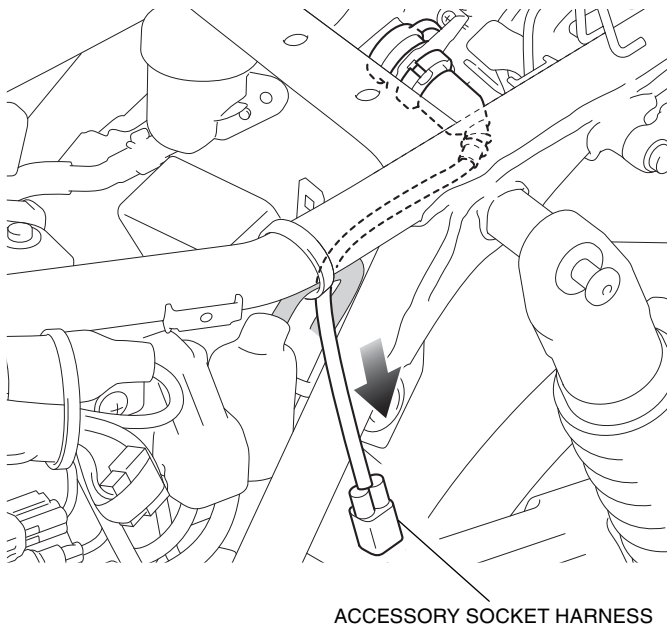

10. Remove the dummy connector as shown.

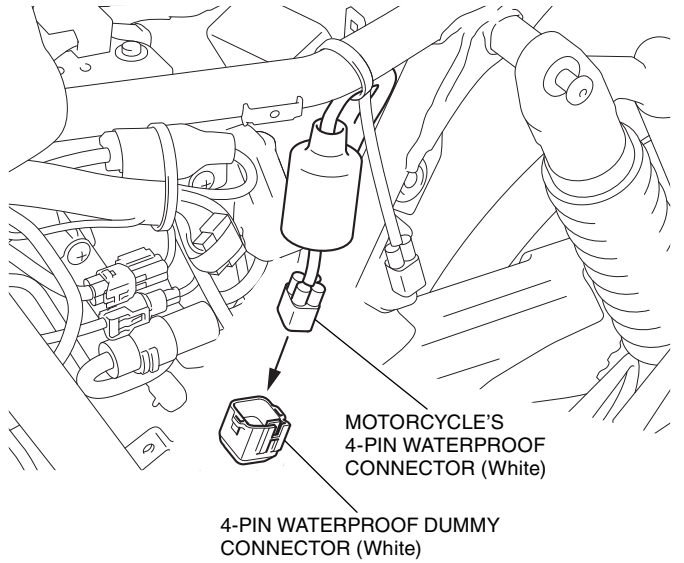

11. Install the dummy connector to the accessory socket sub harness as shown.

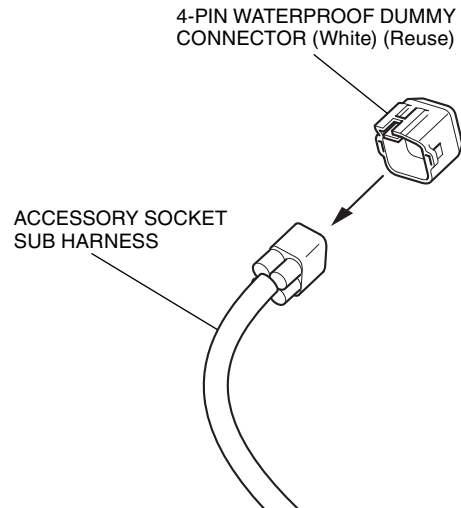

12. Connect the accessory socket sub harness as shown.

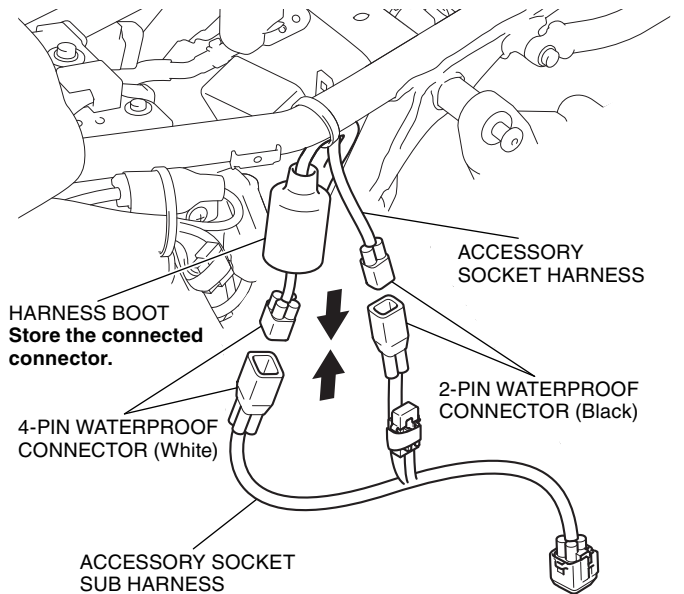

13. Remove the wire tie as shown.

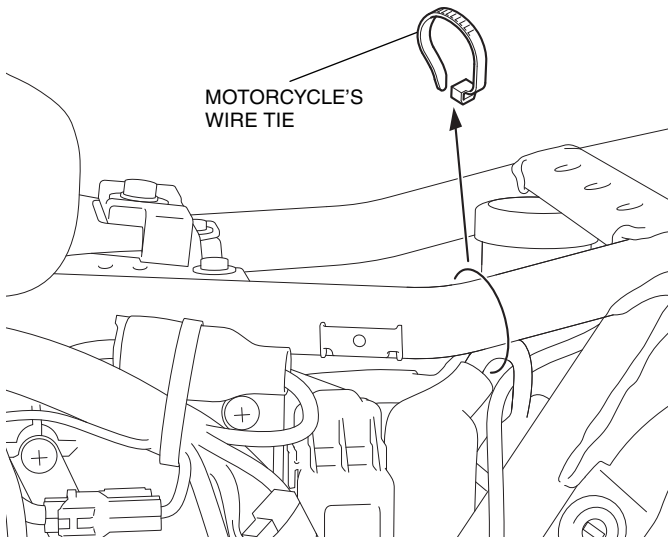

14. Connect two wire ties as shown.

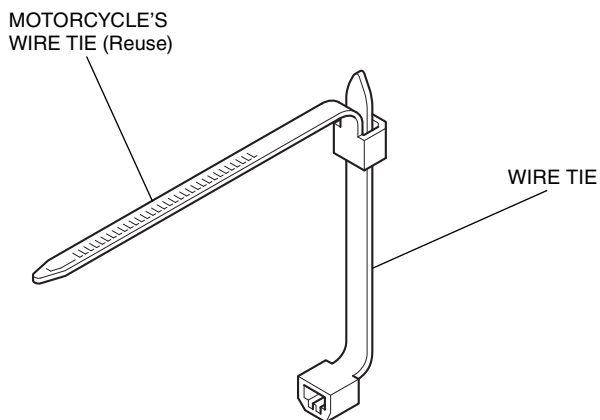

15. Secure the accessory socket harness and the motorcycle harness to the frame with the wire tie as shown.

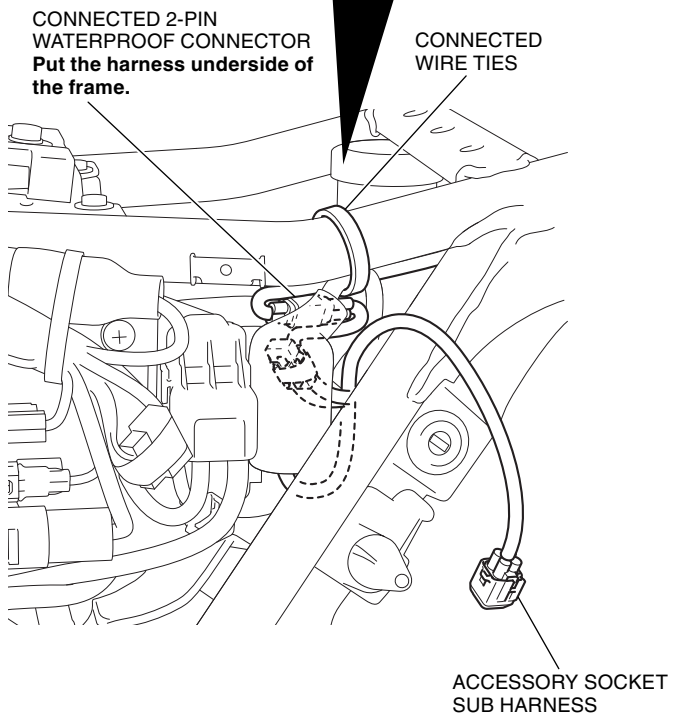
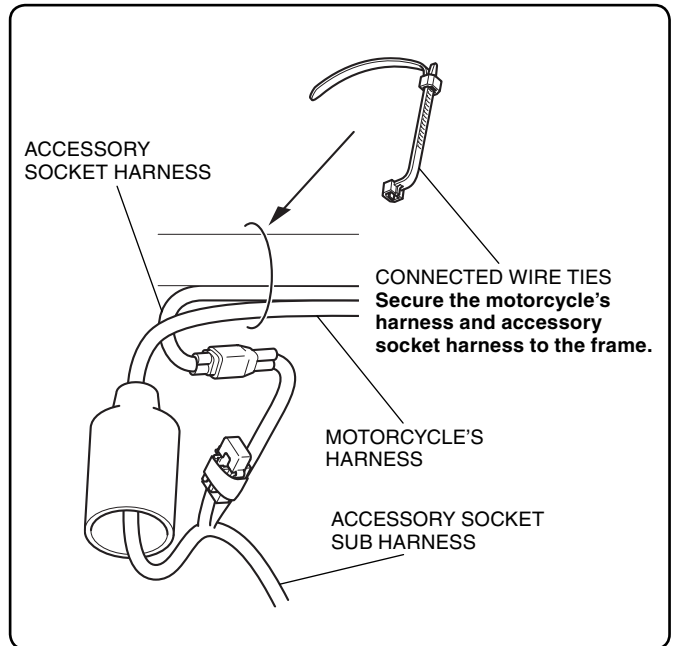

16. Route the accessory socket sub harness with dummy connector as shown.

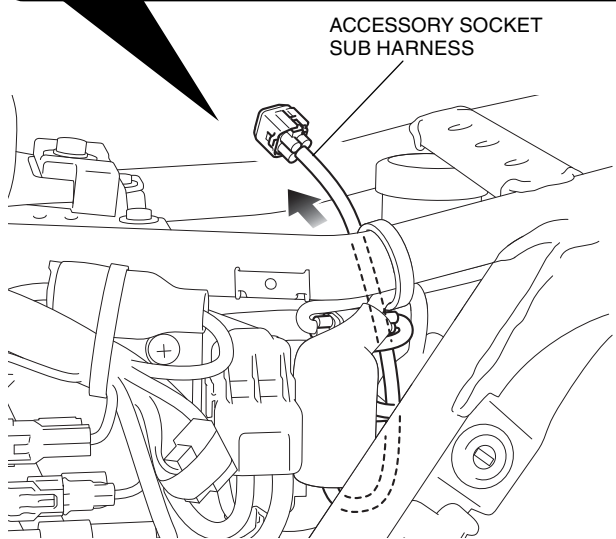
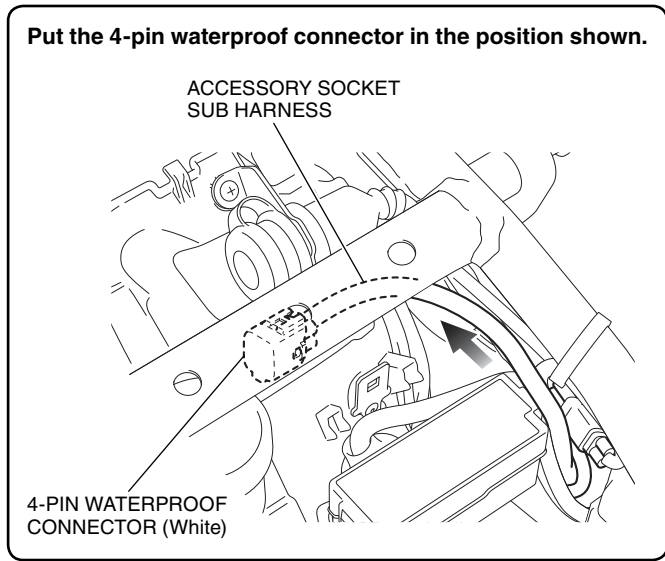

17. Install the motorcycle's parts in the reverse order of removal.
- **Confirm that any wire harness is not caught or too tight.**
18. Check the accessory socket, headlight and the other lights for proper operation.