

Accessory	Application	Publication No.
HEATED GRIPS ATTACHMENT KIT P/N 08T70-MJW-D90	After '15 CB500X/XA	MII 15802
		Issue Date
		March 2016

Honda Dealer: Please give a copy of these instructions to your customer.

PARTS LIST

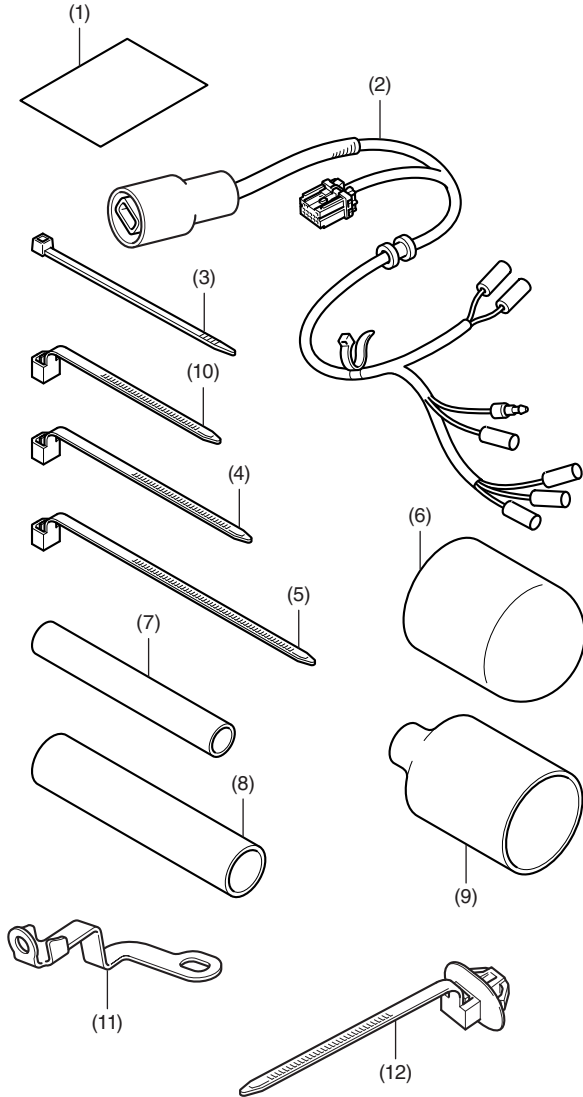

No.	Description	Qty
(1)	Installation Instructions URL	1
(2)	Heated grip harness	1
(3)	Wire tie (narrow)	7
(4)	Wire tie (wide/middle) (Not used.)	3
(5)	Wire tie (wide/long)	3
(6)	Boot cover	1
(7)	Tube (narrow)	2
(8)	Tube (wide)	1
(9)	Harness boot	1
(10)	Wire tie (wide/short)	2
(11)	Clamp	1
(12)	Clip band	1

HEATED GRIP KIT Sold separately

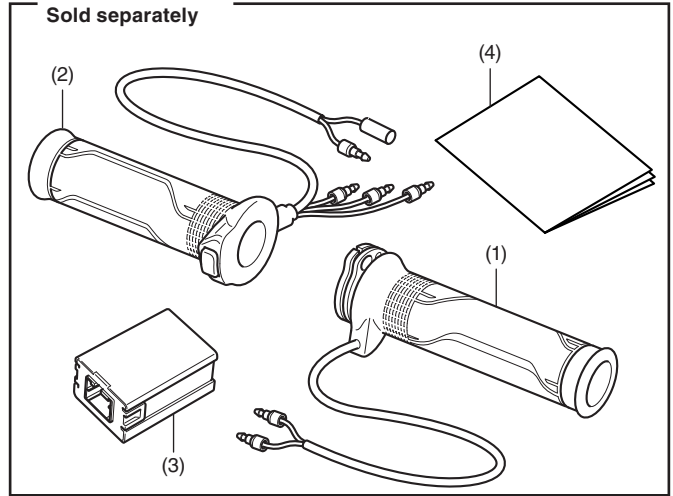

No.	Description	Qty
(1)	Right heated grip	1
(2)	Left heated grip	1
(3)	Controller	1
(4)	Owner's Manual	1

TOOLS AND SUPPLIES REQUIRED

- Side cutters
- Ruler
- Marker
- Electrical tape
- Pro Honda Handgrip Cement
- Grease
- Isopropyl alcohol
- Shop towel

TORQUE CHART

Refer to the Service Manual for the torque values of the removed parts.

INSTALLATION

▲ CAUTION

- To prevent burns, allow the engine, exhaust system, radiator, etc., to cool before installing the accessory.

NOTE:

- Disconnect the throttle cable from the right grip as instructed in the motorcycle's Service Manual.
- For secure adhesion of the heated grips use the recommended adhesive agent (Pro Honda Handgrip Cement) or equivalent.
- Be sure to open and close the throttle to check for smooth operation in any steering position after installation of the right heated grip.
- Disconnect the negative (-) cable from the battery before installing this accessory.
- The clock will be erased when you disconnect the battery. Reset the clock after reconnecting the battery.
- Reinstall the removed parts on the motorcycle and make sure that the wires and harnesses are not pinched.
- Trim the excess ends off the wire ties after attaching them to the wire harnesses. Do not allow the cut part of the wire tie to interfere with another harness or brake hose.
- After heated grip installation, check the lights (e.g. right / left turn signal lights and brake lights) for proper operation.

1. Remove the seat and disconnect the negative (-) cable of the battery.

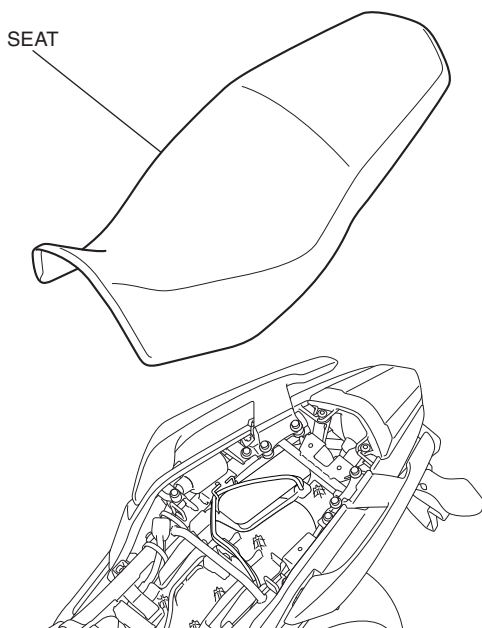

2. Remove the left side cover as shown.

<Left side>

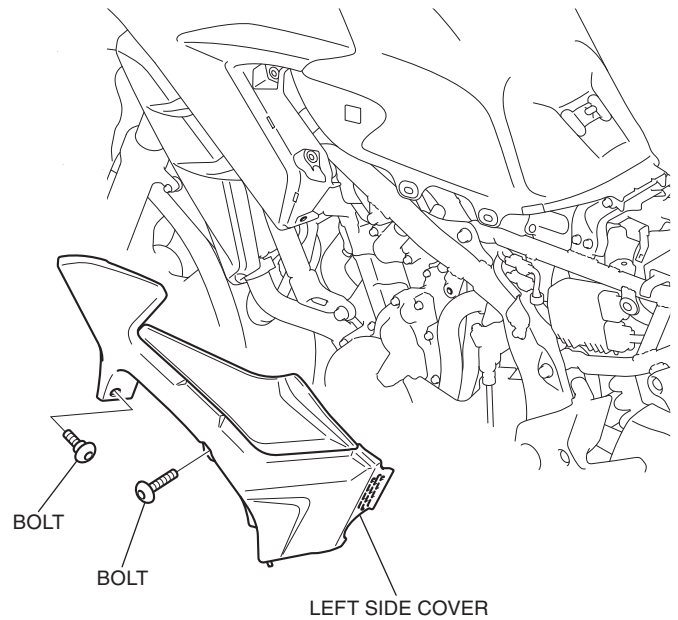

3. Remove the left shroud as shown.

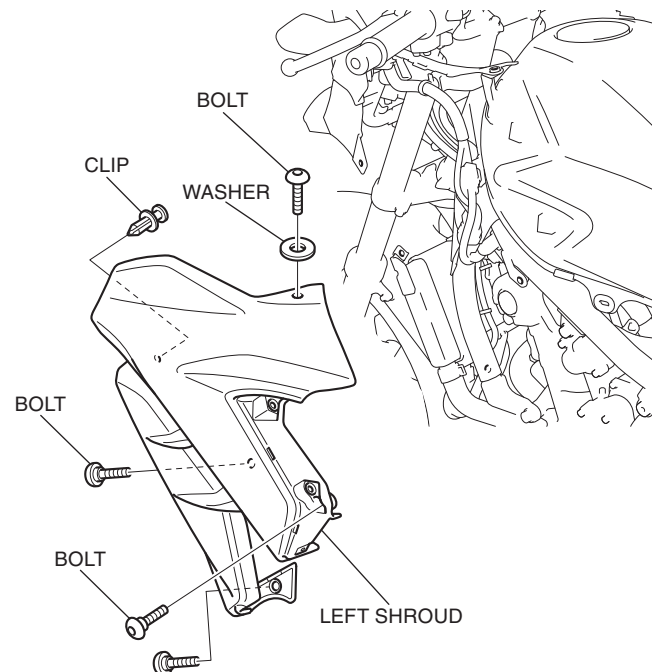

4. Remove the left inner cowl as shown.

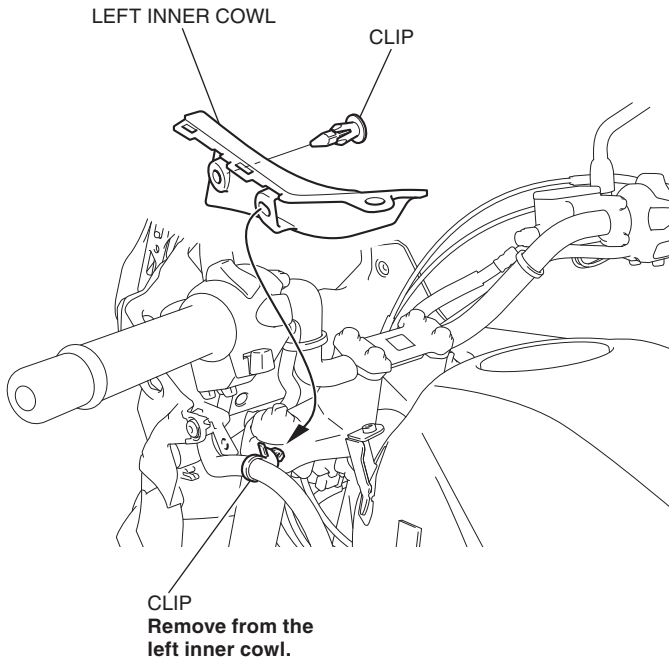

5. Remove the right side cover, right shroud and right inner cowl in the same manner as the left side.

6. Remove the meter panel as shown.

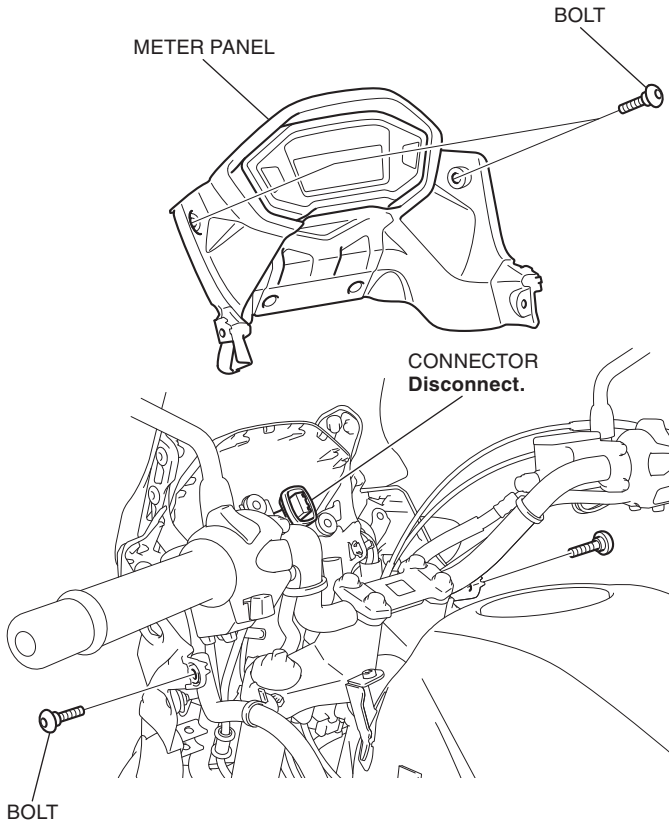

7. Remove the handlebar weight as shown.

- Repeat on the left side.

<Right side>

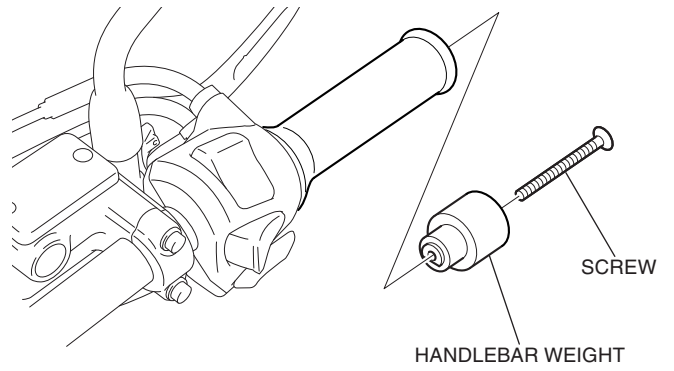

8. Remove the right handlebar switch as shown.

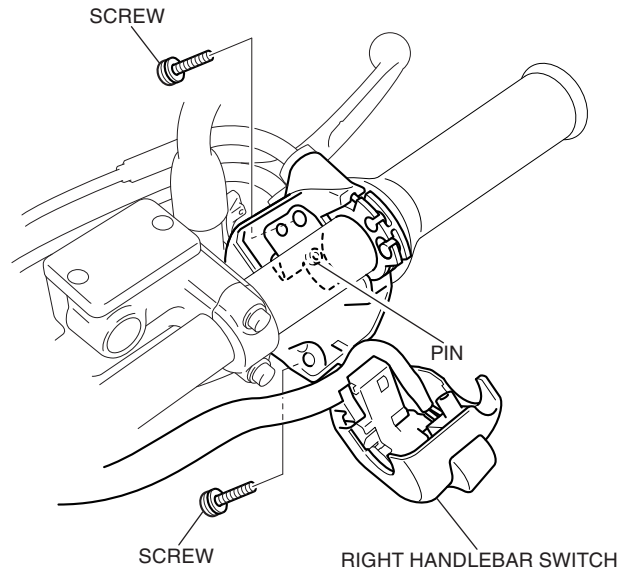

9. Remove the right grip as shown.

NOTE

Disconnect the throttle cable from the right grip as instructed in the motorcycle's Service Manual. Do not try to disconnect the cable with force using pliers, etc.

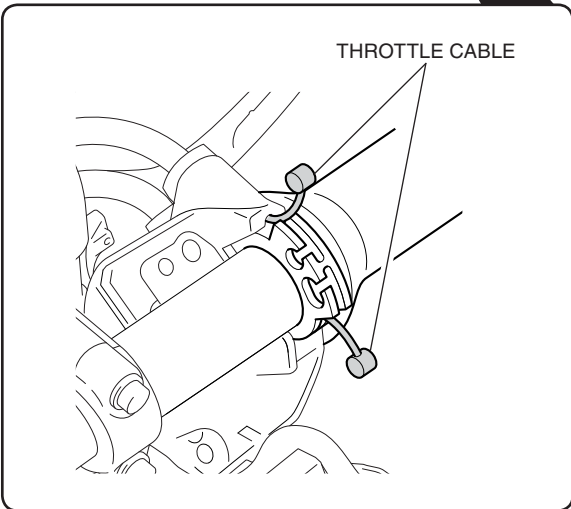
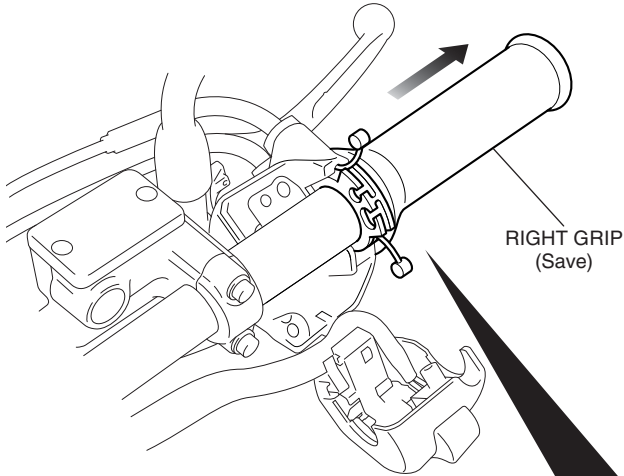

10. Mark the right heated grip harness in the position shown.

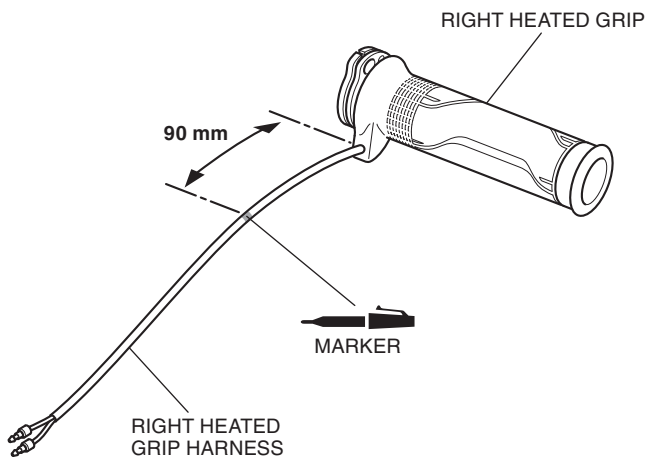

11. Install the clip band on the marked position as shown.

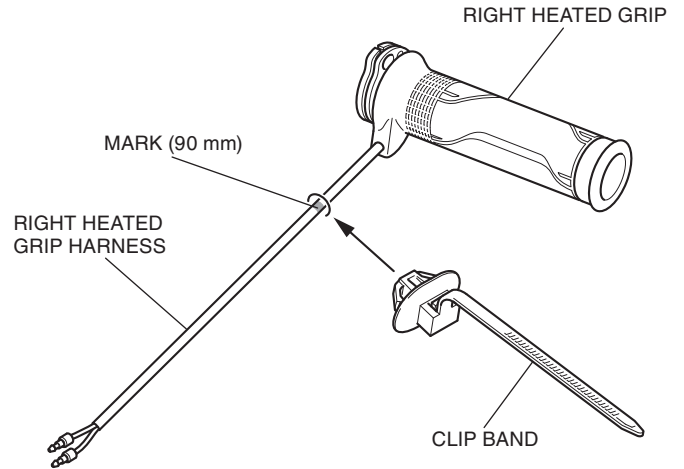

12. Apply grease to the  parts of the throttle cables and throttle pipe as shown.

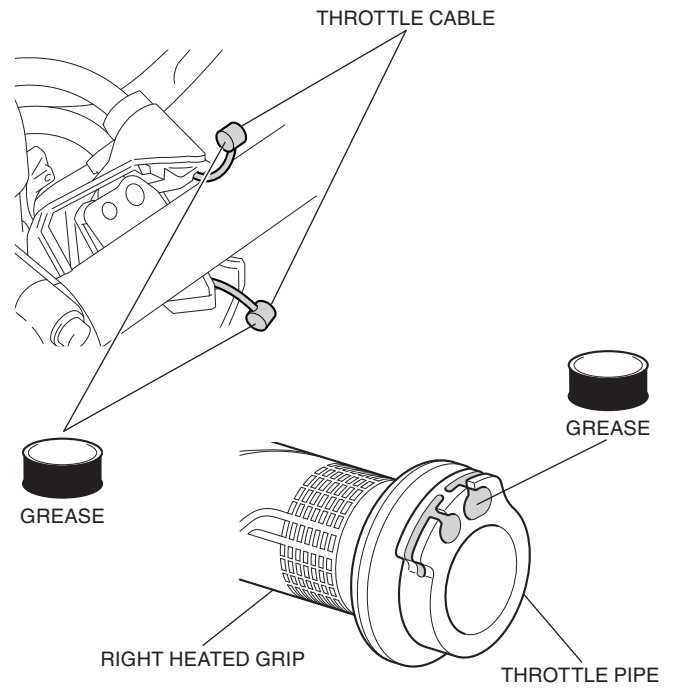

13. Install the right heated grip in the reverse order of the motorcycle's grip removal.

- After installation, refer to the Service Manual and adjust the throttle freeplay.

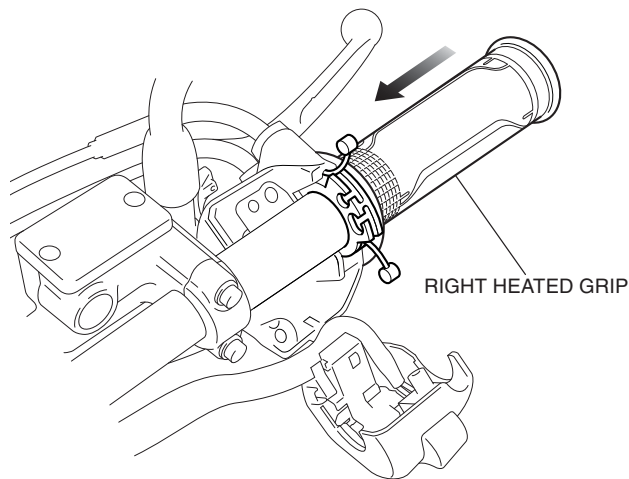

14. Open and close the throttle grip as shown.

- Check for smooth opening of the throttle and that it automatically snaps closed from any opening, in all steering positions.

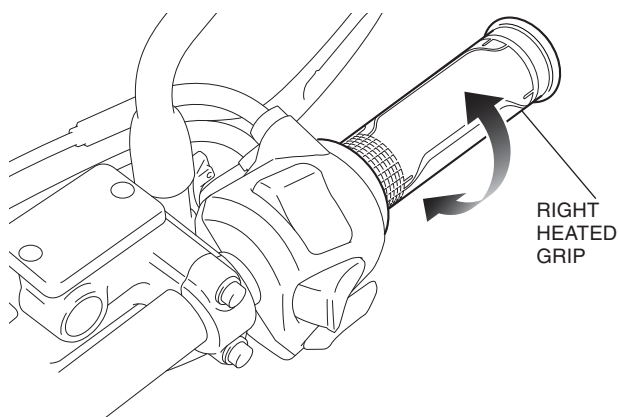

15. Remove the bolt as shown.

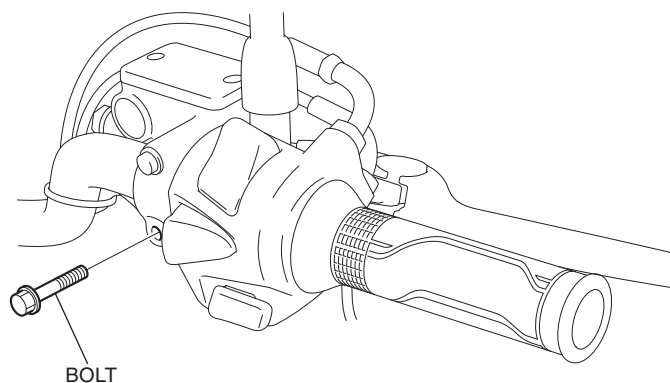

16. Install the clamp as shown.

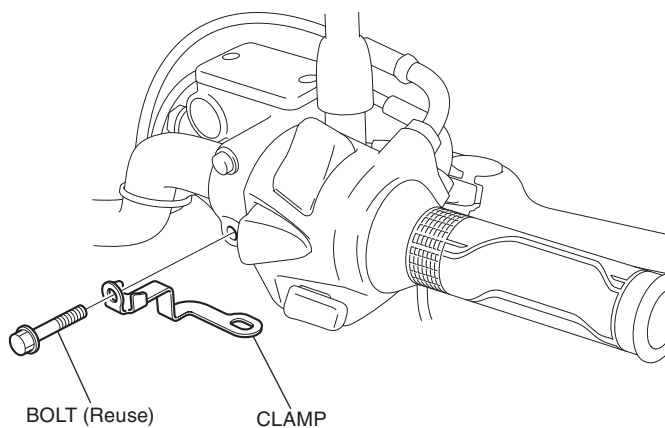

17. Secure the right heated grip harness as shown.

- Open and close the throttle and confirm that there is no tightness of the heated grip harness.

<Right side>

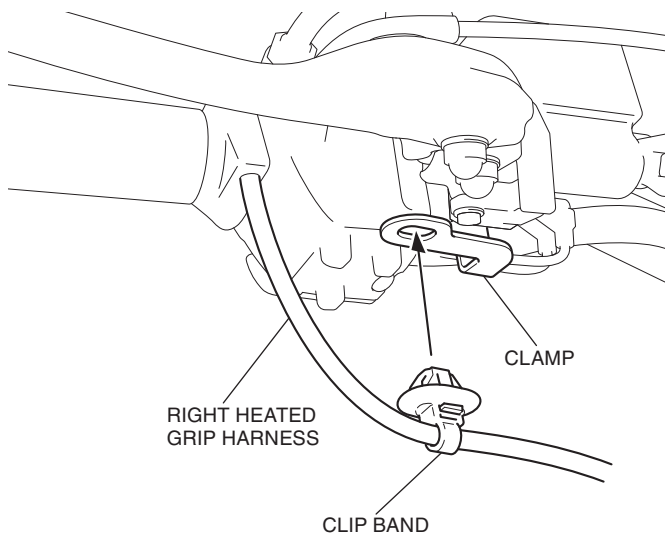

18. Route the right heated grip harness as shown.

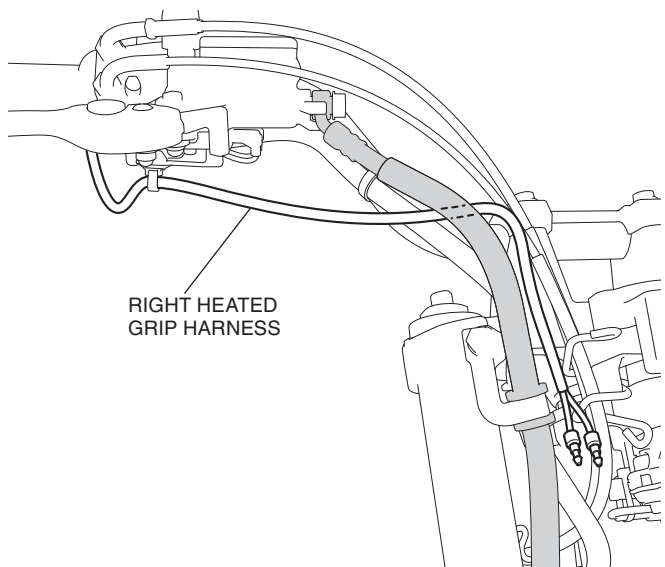

19. Remove the left grip as shown.

<Left side>

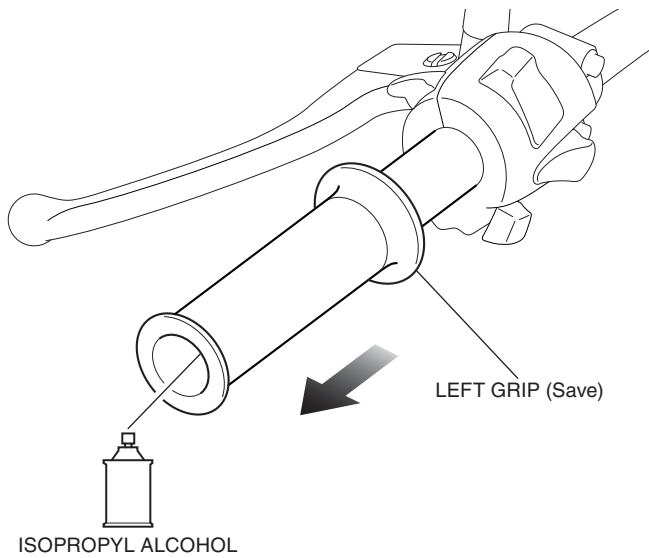

20. Using a isopropyl alcohol, remove all traces of adhesive from the left handlebar.

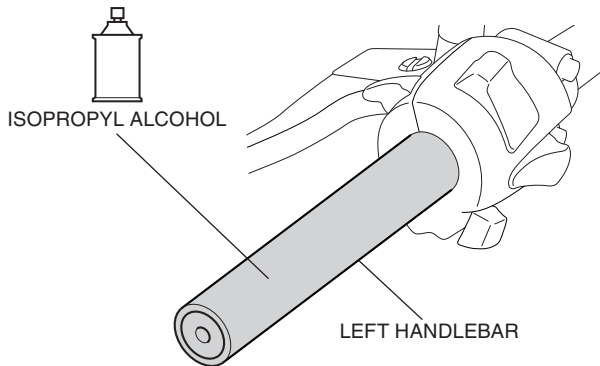

21. Liberally apply Pro Honda Handgrip Cement to the inside of the left heated grip as shown.

NOTE

Read the Instructions of steps 21 through 24 carefully before installation and complete the operation quickly before the adhesive cures. Use an assistant to steady the motorcycle while installing the grip.

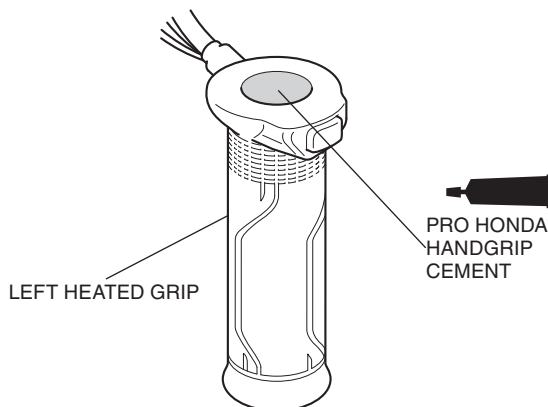

22. Apply Pro Honda Handgrip Cement to the left handlebar as shown.

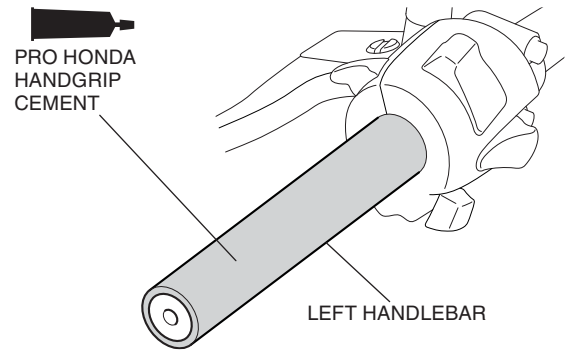

23. Spray isopropyl alcohol over the entire inside of the left heated grip and outside of the left handlebar.

- This is done to ease installment of the heated grip onto the handlebar.

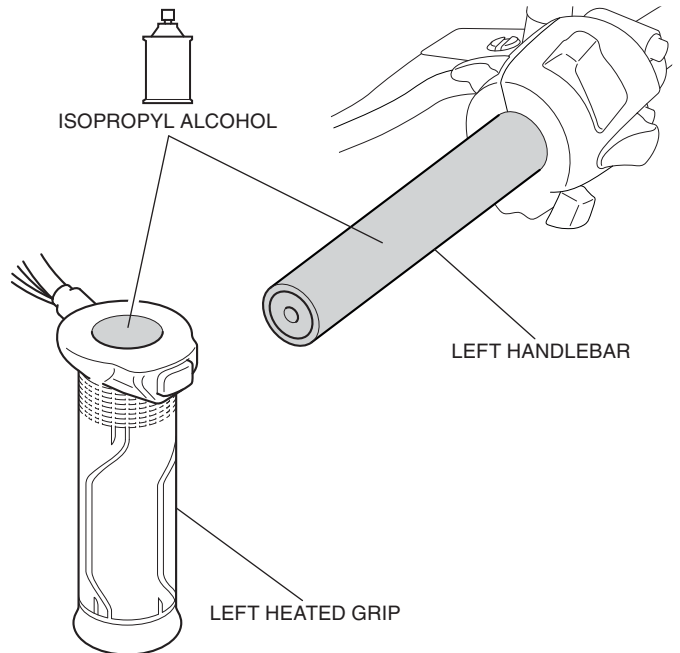

24. Slide the left heated grip onto the left handlebar as indicated.

- Wipe up any excess adhesive at once.

NOTICE

- Do not tap on the grip end with a hammer and do not twist the grip to install the heated grip onto the handlebar, as it can damage the element.

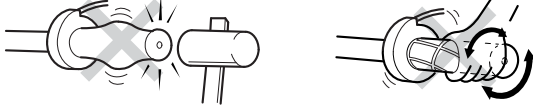

- Avoid putting pressure on the switch part when inserting the left heated grip. There is a possibility that the switch part will break. Also, install so that there is no gap with the switch holder.



- If the grip gets stuck halfway during installation, apply isopropyl alcohol to the gap between the heated grip. Do not try to remove the heated grip using force or a screwdriver, etc. Damage to the heated grip wire can result.

Insert until there is contact with the left handlebar switch, then align with the indicated position.

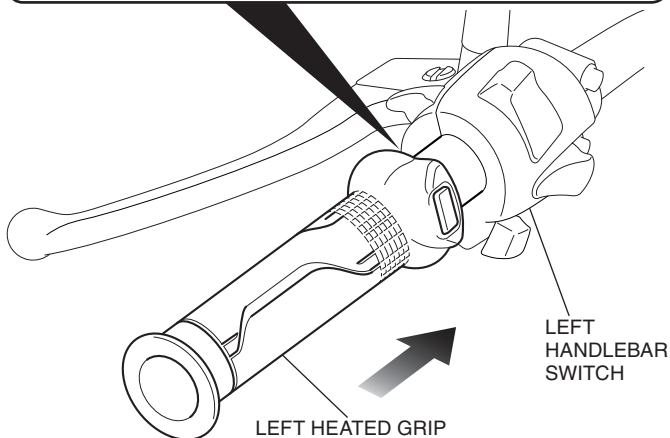
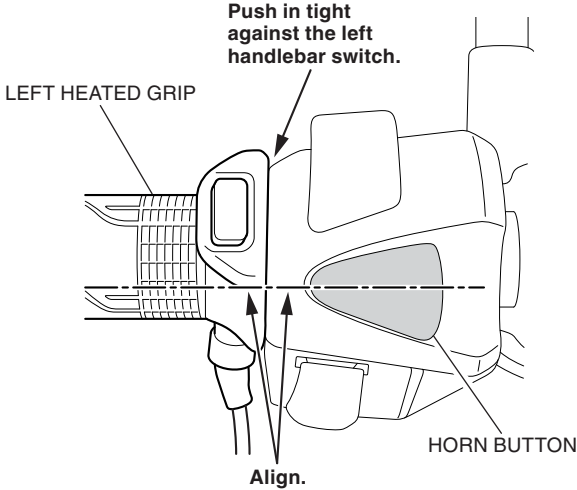

25. Remove the parts as shown.

<Front side>

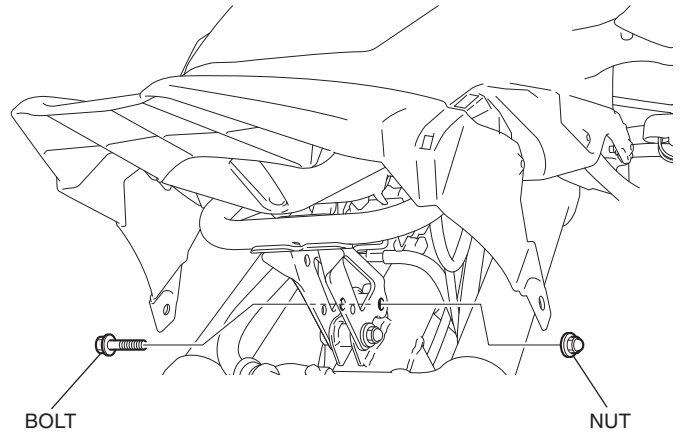

26. Move the front upper cowl as shown.

- Protect with a shop towel or similar, and take care not to damage the front upper cowl.

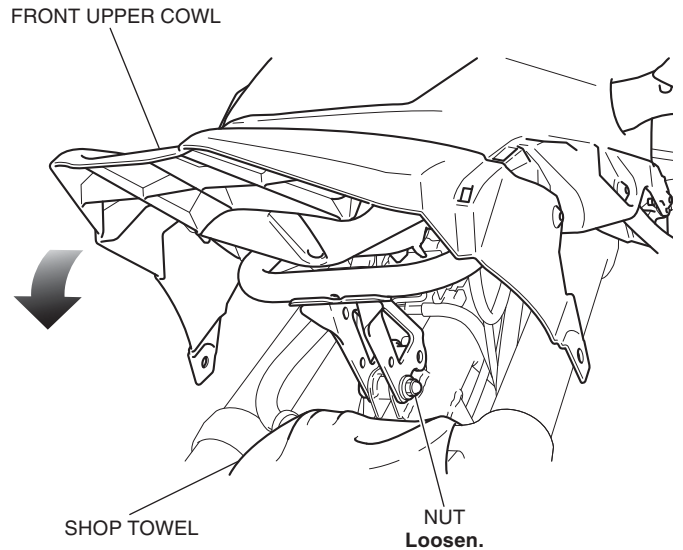

27. Pass the harness boot through the heated grip harness as shown.

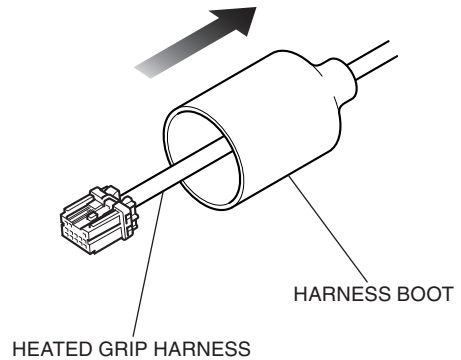

28. Connect the controller as shown.

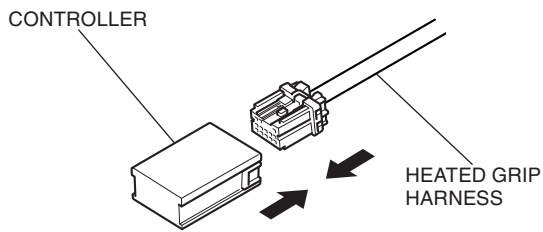

29. Fit the harness boot over the controller as shown.

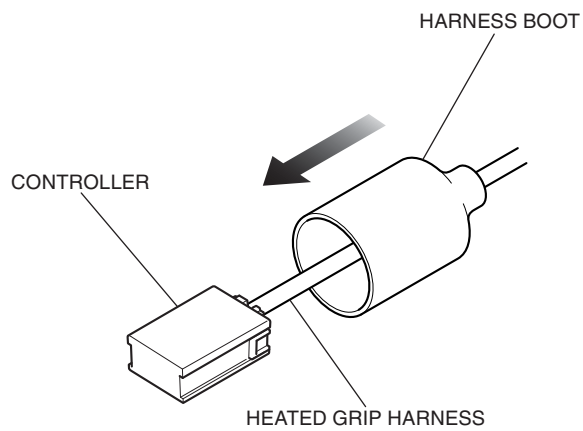

30. Fit the boot cover over the harness boot as shown.

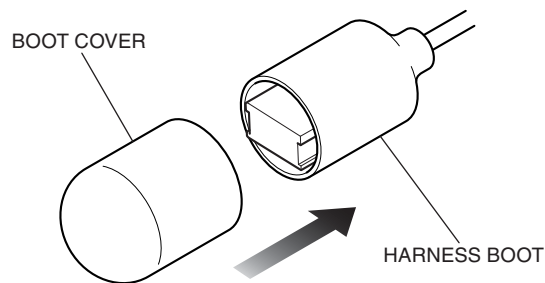

31. Secure the boot cover with electrical tape as shown.

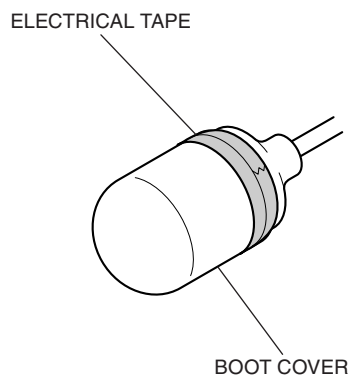

32. Cut the [shaded area] area of the tube as shown.

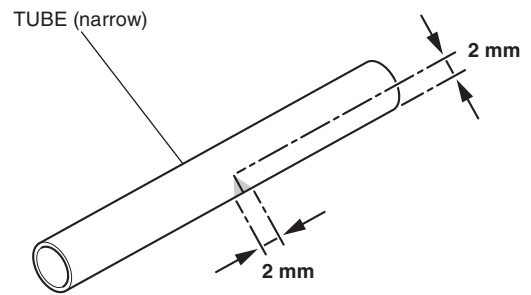

33. Pass the tube and cut tube over the heated grip harness as shown.

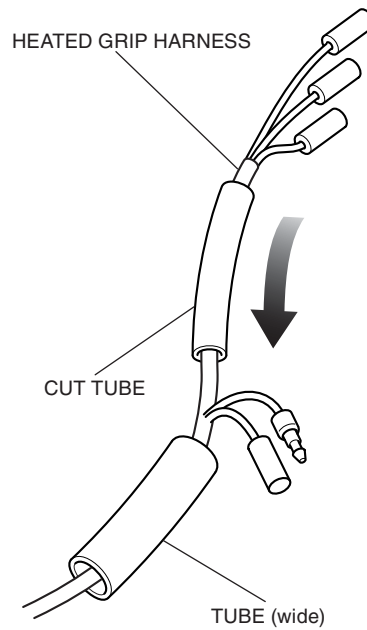

34. Connect the heated grip harness as shown.

<Left side>

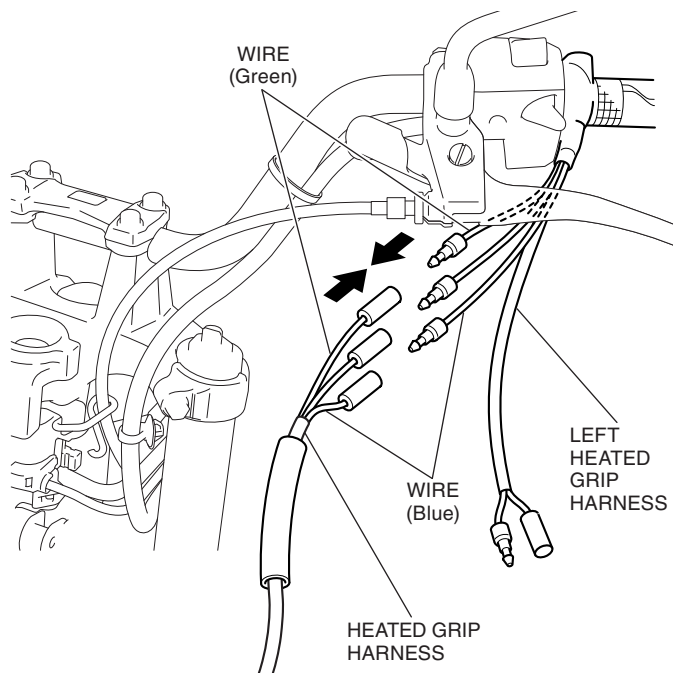

35. Slide the tube as shown.

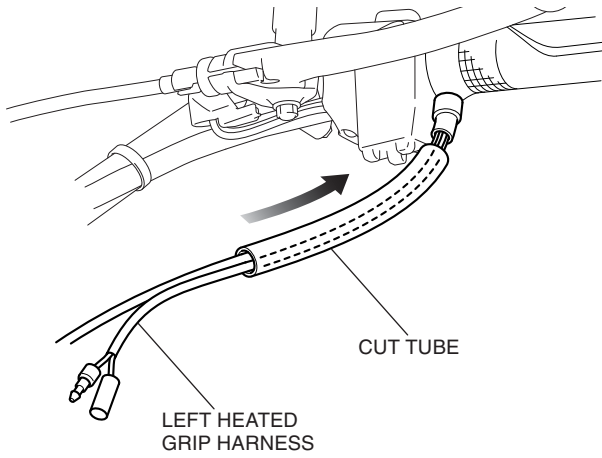

36. Secure the tube with electrical tape as shown.

- Secure the tube with its cutout facing down as shown.

Confirm that the rubber end is in contact with the base of the heated grip.

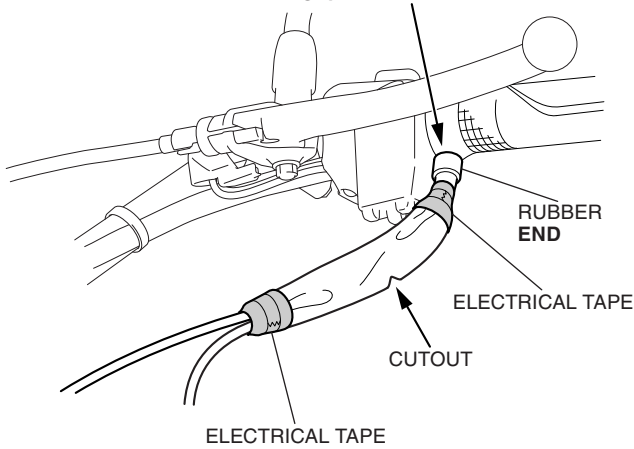

37. Connect the heated grip harness as shown.

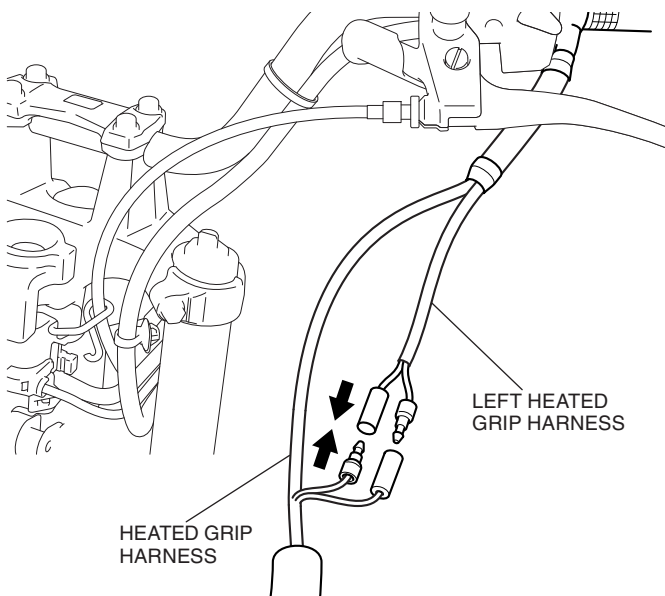

38. Slide the tube as shown.

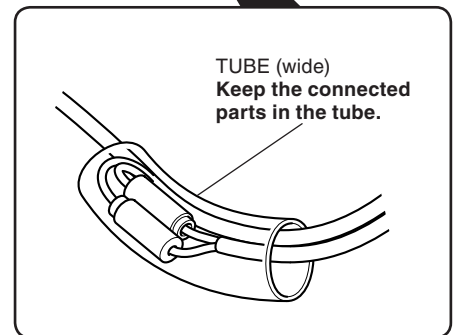
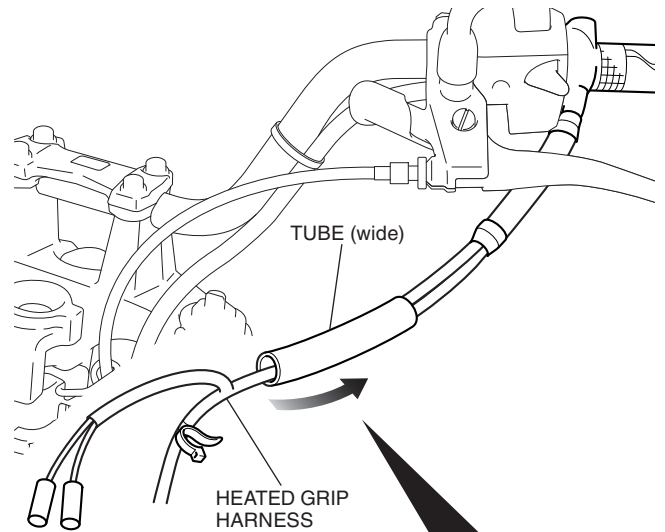

39. Pass the grip heater harness through the tube as shown.

<Right side>

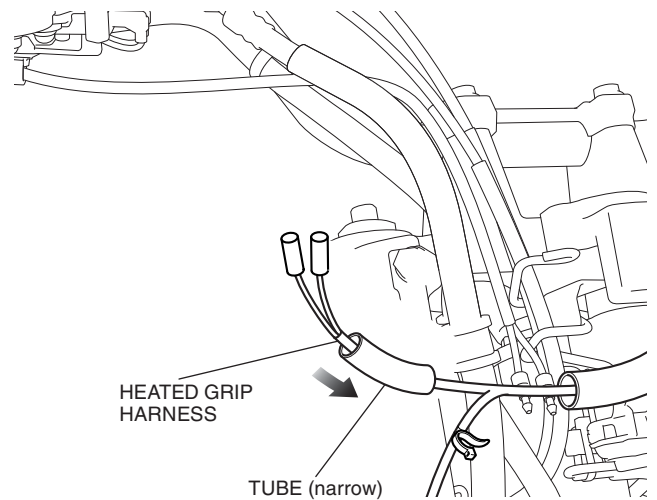

40. Connect the right heated grip harness as shown.

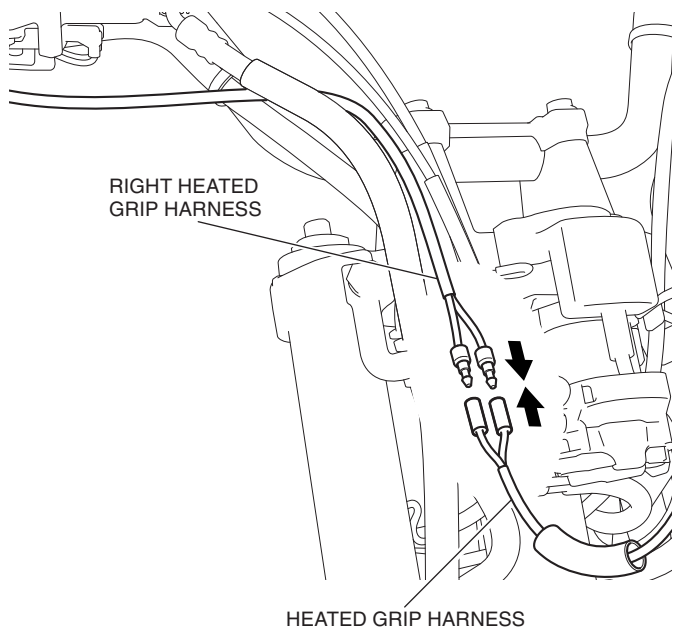

41. Slide the tube as shown.

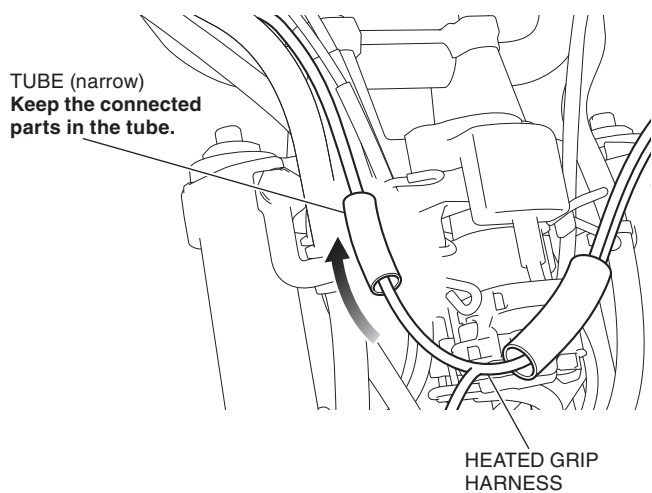

42. Secure the tube with electrical tape as shown.

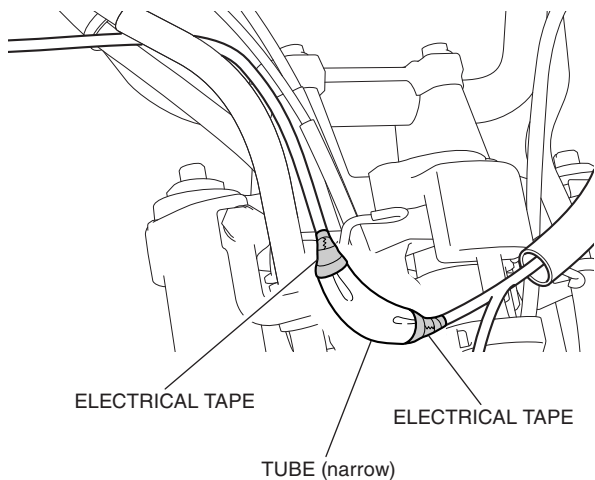

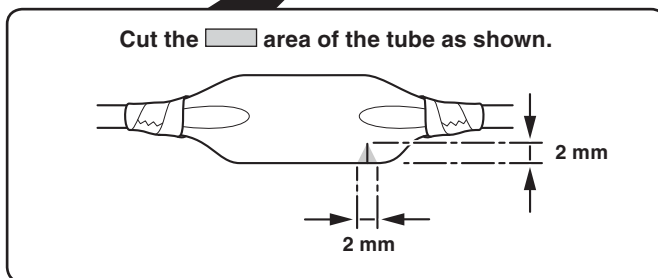
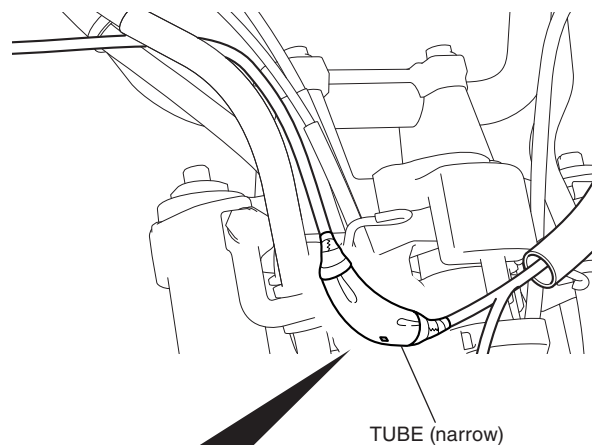

43. Cut the [] area of the tube as shown.

- Be careful not to damage harnesses.

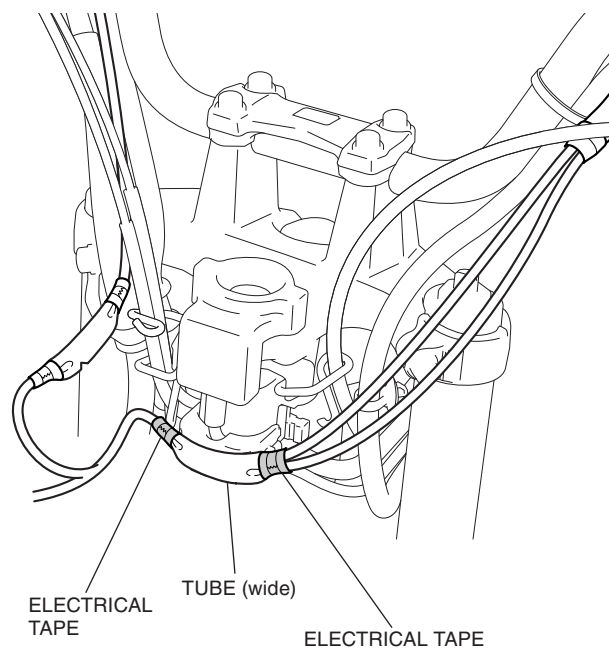

44. Secure the tube with electrical tape as shown.



45. Cut the  area of the tube as shown.
- **Be careful not to damage harnesses.**

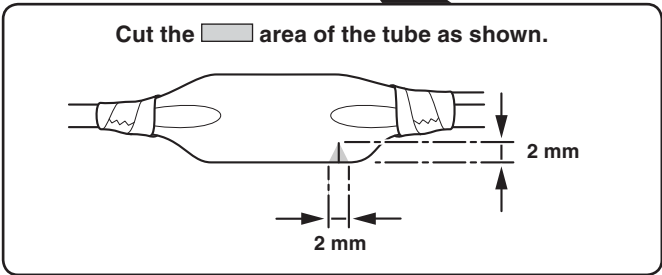
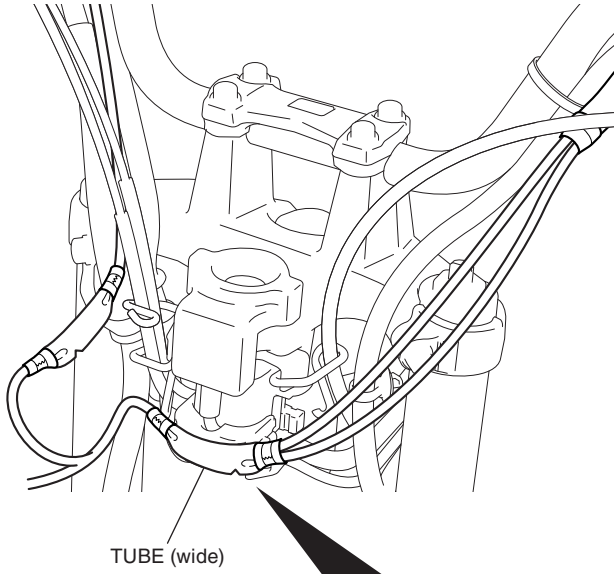

46. Loosely install the wire tie as shown.

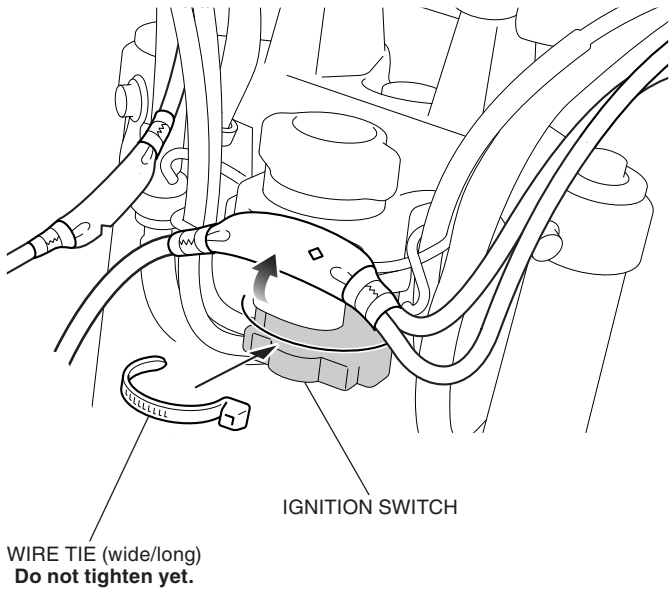

47. Secure the tube with the wire ties as shown.

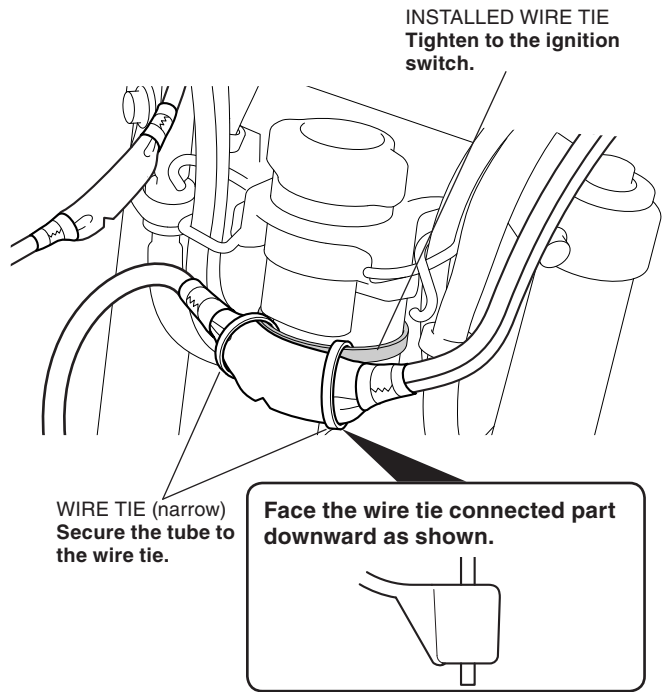

48. Secure the heated grip harness and left heated grip harness with the wire tie as shown.

<Left side>

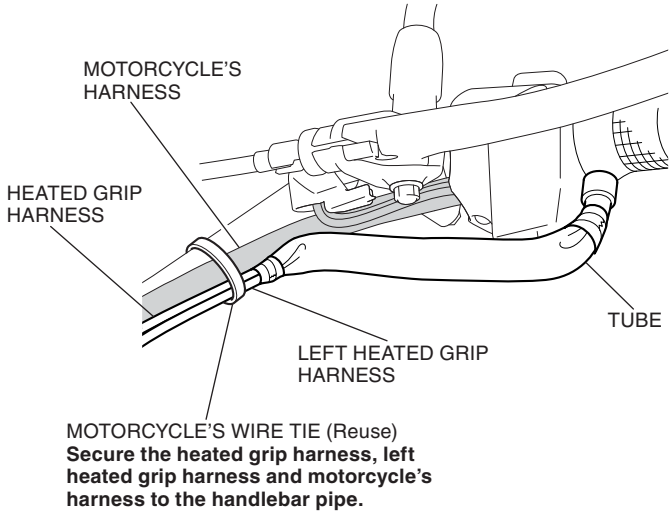

49. Secure the tube with the wire tie as shown.

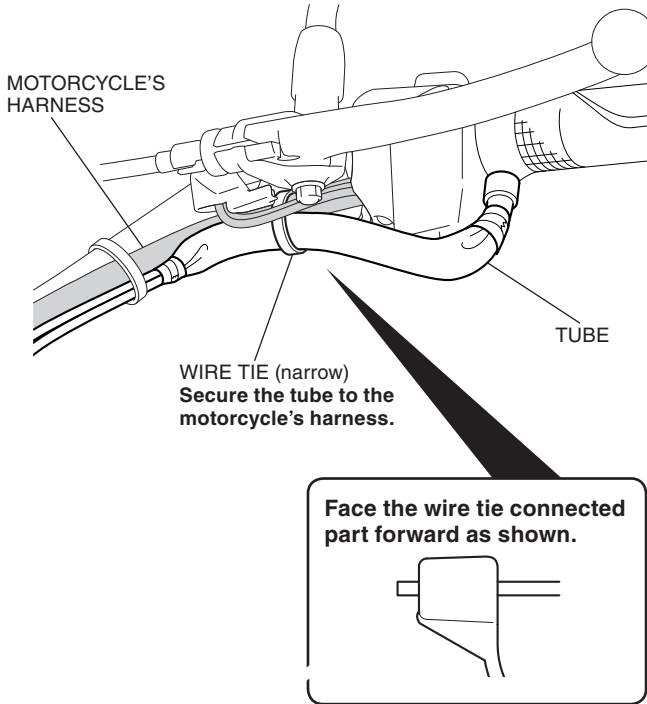

50. Secure the right heated grip harness with the wire ties as shown.

<Right side>

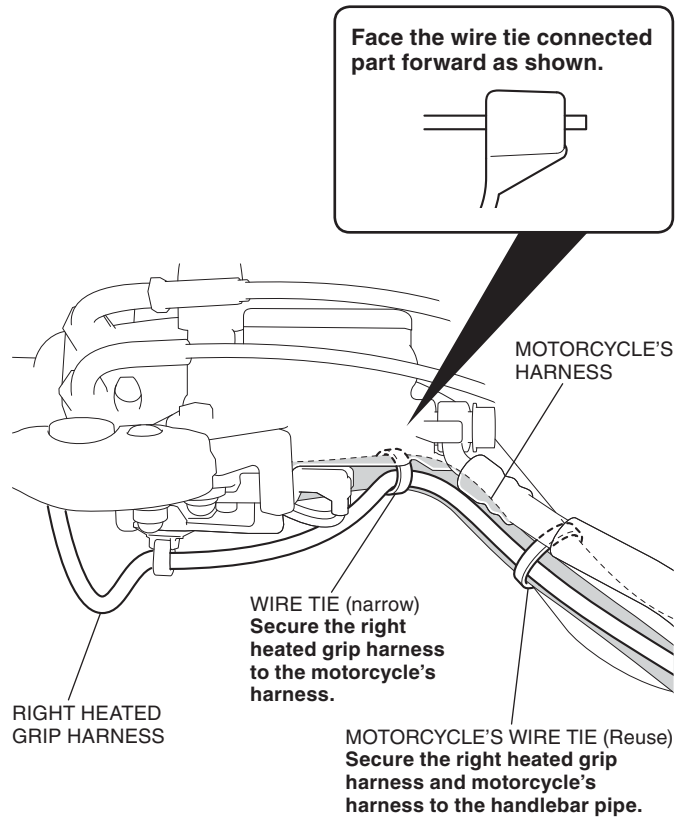

51. Secure the heated grip harness with the wire ties as shown.

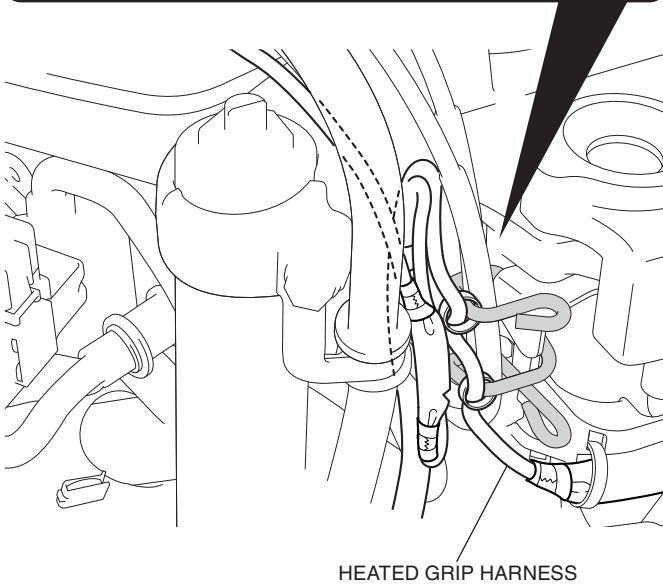
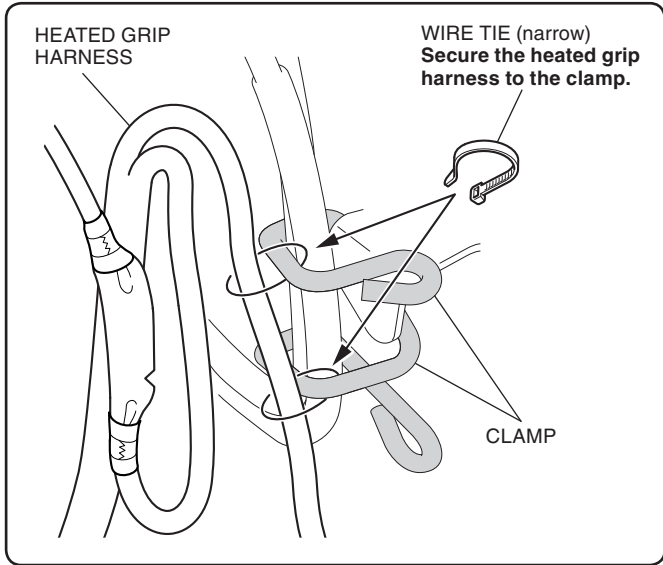

52. Secure the heated grip harness with the wire tie as shown.

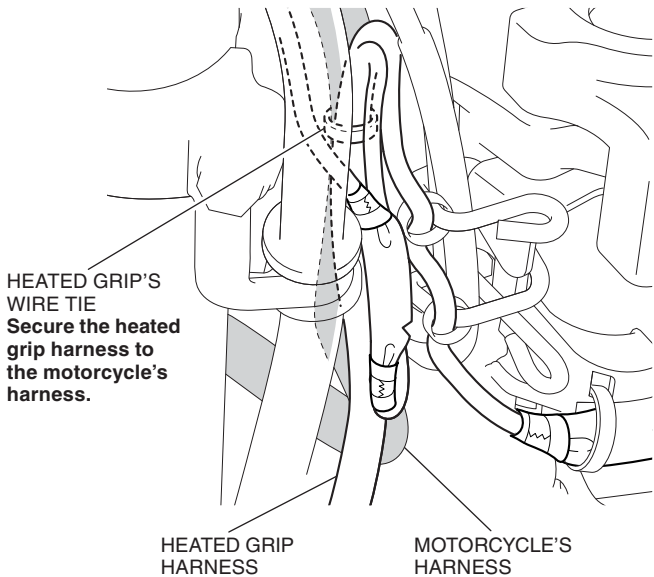

53. Route the heated grip harness as shown.

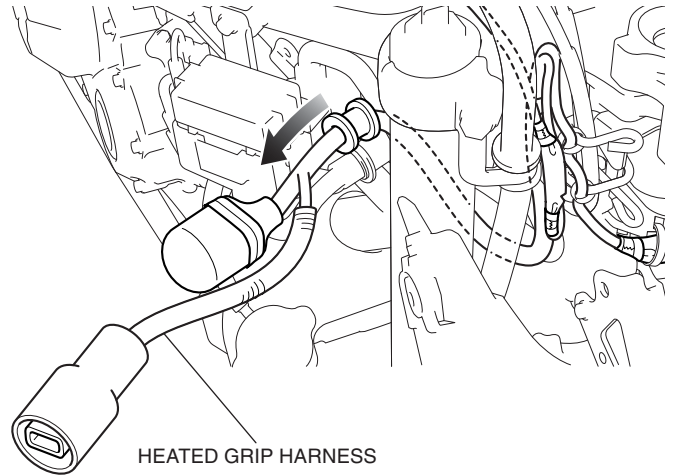

54. Connect two wire ties as shown.

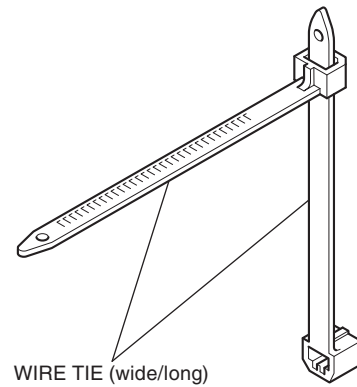

55. Secure the heated grip harness and boot cover with the wire ties as shown.

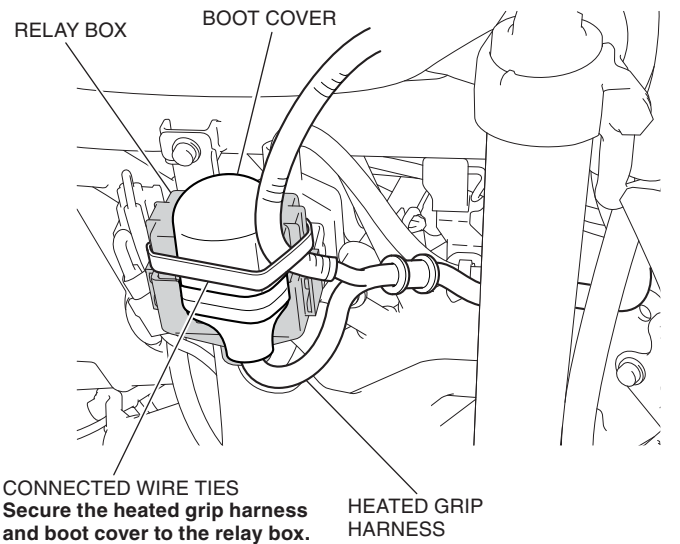

56. Secure the heated grip harness with the wire tie as shown.

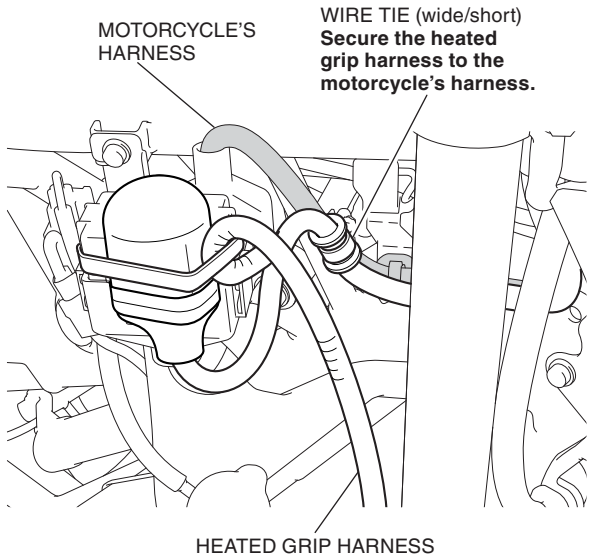

57. Route the heated grip harness as shown.

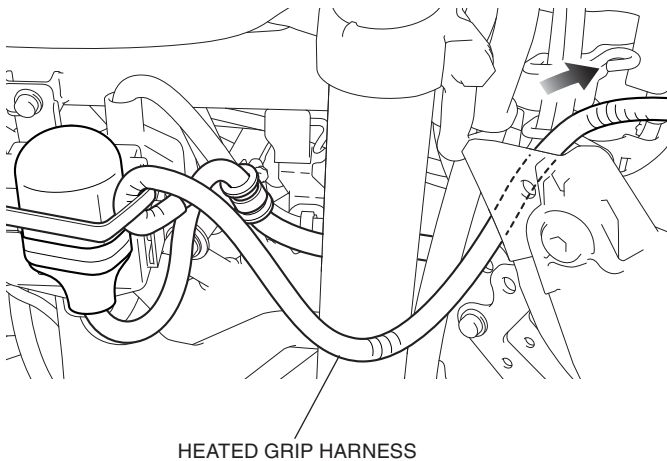

58. Remove the dummy connector as shown.

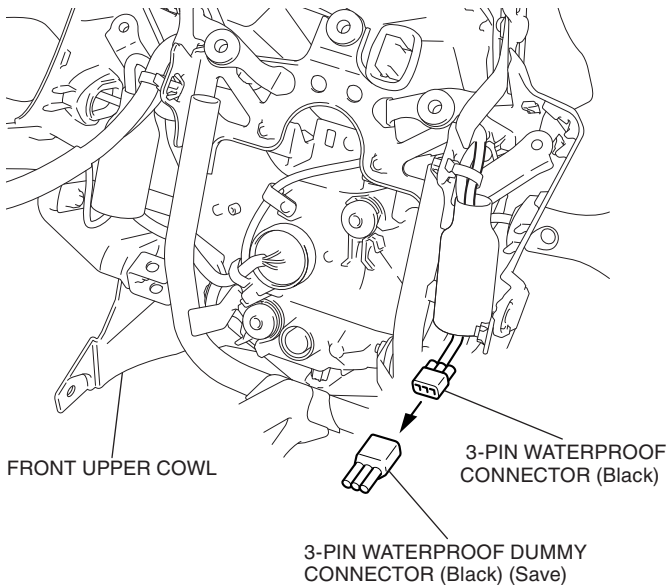

59. Connect the heated grip harness as shown.

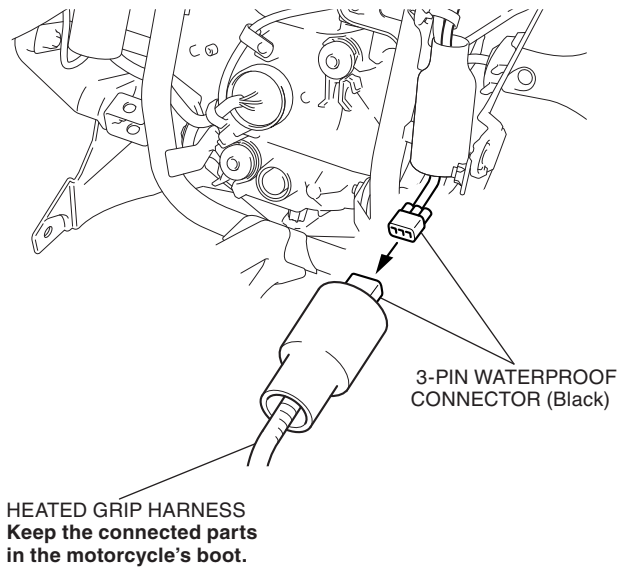

60. Install the front upper cowl in the reverse order of removal.

61. Install the meter panel, right inner cowl and right shroud in the reverse order of removal.

62. Secure the heated grip harness with the wire tie as shown.

<Right side>

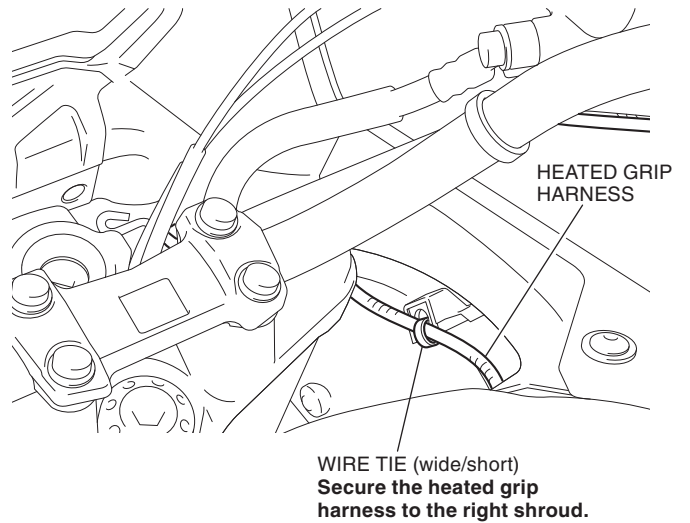

63. Install the motorcycle's parts in the reverse order of removal.
 - **Confirm that no harness is caught or too tight.**
64. Check each harness for sufficient freeplay.
 - **Move the handlebar right and left and check that the harnesses are not pinched by the neighboring components and that they are not pulled taut.**
65. Check the heated grip, head light and the other lights for proper operation.