



INSTALLATION INSTRUCTIONS

Accessory	
CARBON FIBER KIT	P/N 08P61-MGE-200
TANK PAD	P/N 08P61-MGE-200A
FUEL LID COVER	P/N 08P61-MFJ-100B
IGNITION KEY TRIM	P/N 08P61-MGE-200C

Application
VFR1200F

Publication No.
MII 13494
Issue Date
December 2010

Honda Dealer: Please give a copy of these instructions to your customer.

PARTS LIST

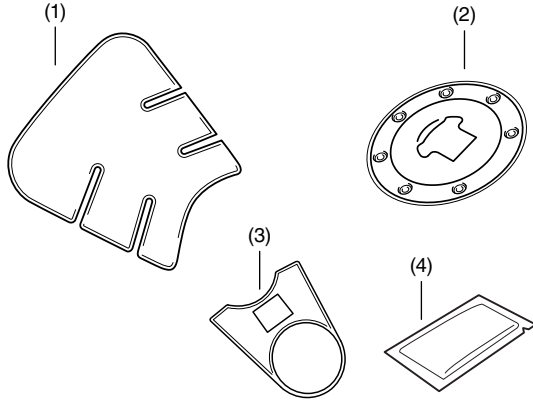

No.	Description	Qty
(1)	Tank pad	1
(2)	Fuel lid cover	1
(3)	Ignition key trim	1
(4)	Alcohol pad	1

INSTALLATION

NOTE:

- Heat the bonding surfaces with a hair dryer if the ambient air temperature is below 70°F (21°C).
- The adhesive reaches full strength in 72 hours. Wait at least 24 hours before riding your motorcycle.

1. Remove the steering stem nut plastic cap. Clean the surface of the area shown using an alcohol pad.

ALCOHOL PAD
Thoroughly clean the area where ignition key trim will be attached.

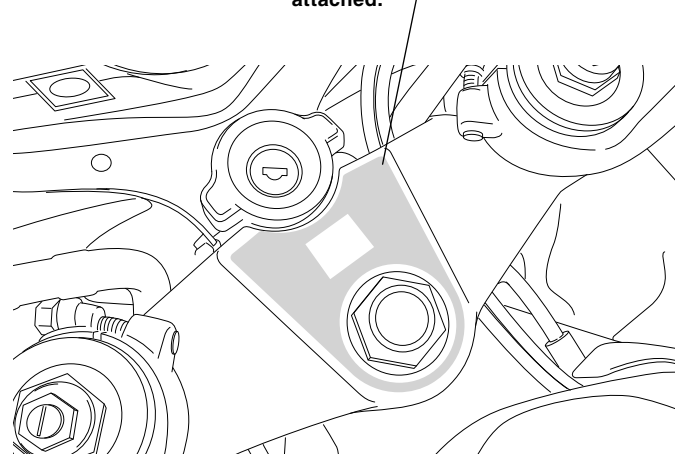

ALCOHOL PAD
Thoroughly clean the areas where tank pad and fuel lid cover will be attached.

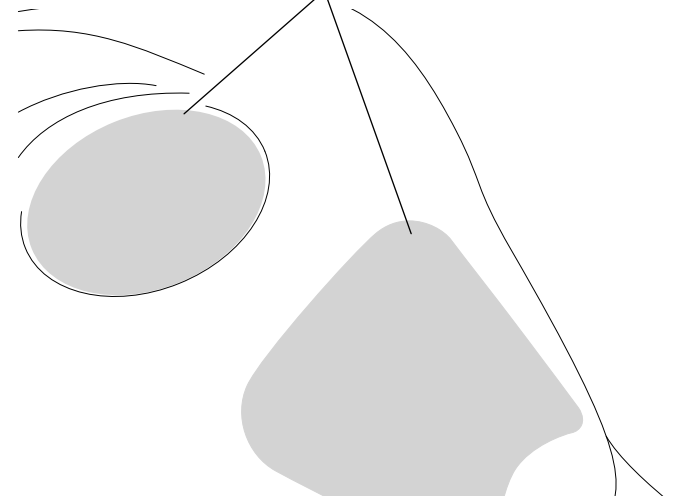

2. Attach the ignition key trim and tank pad. Install the steering stem nut plastic cap in the position shown.

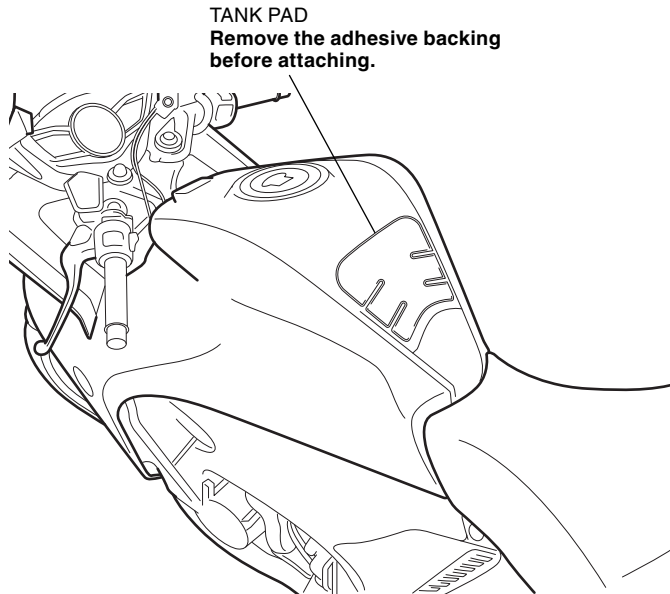
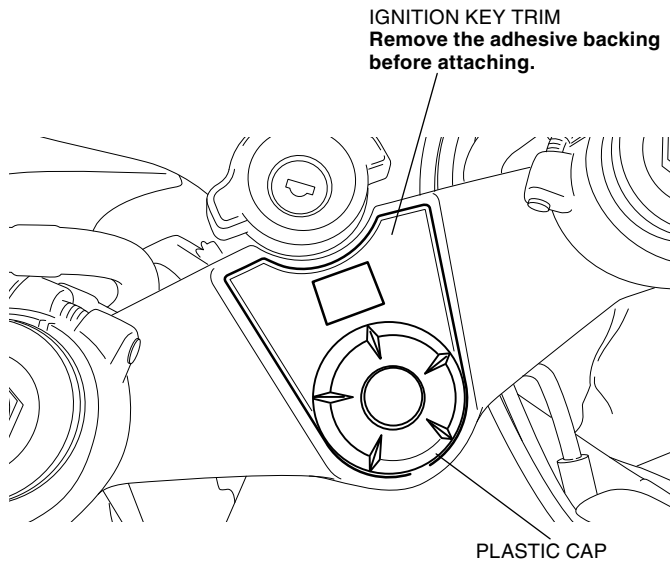

3. Attach the inner ring pad by carefully aligning the edge.

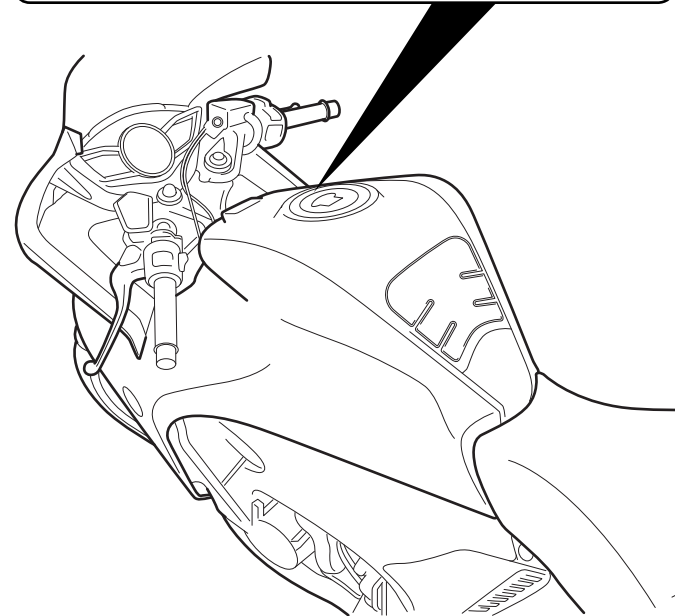
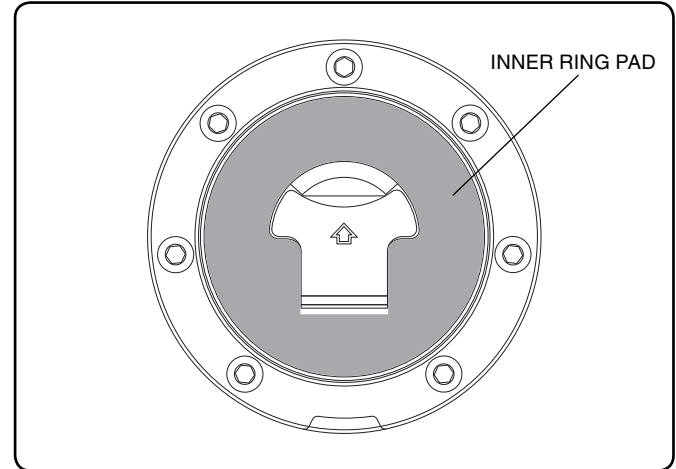

4. Attach the outer ring and cap pad components. Make sure the contour of the pads is parallel with the edges of the corresponding motorcycle parts.

