



INSTALLATION INSTRUCTIONS

Accessory

SADDLEBAG SUPPORT BRACKETS
P/N 08L73-MGS-A30

Application

2012 Only
NC700X/XD

Publication No.

MII 13973-14449

Issue Date
Revised:
February 2013

Honda Dealer: Please give a copy of these instructions to your customer.

PARTS LIST

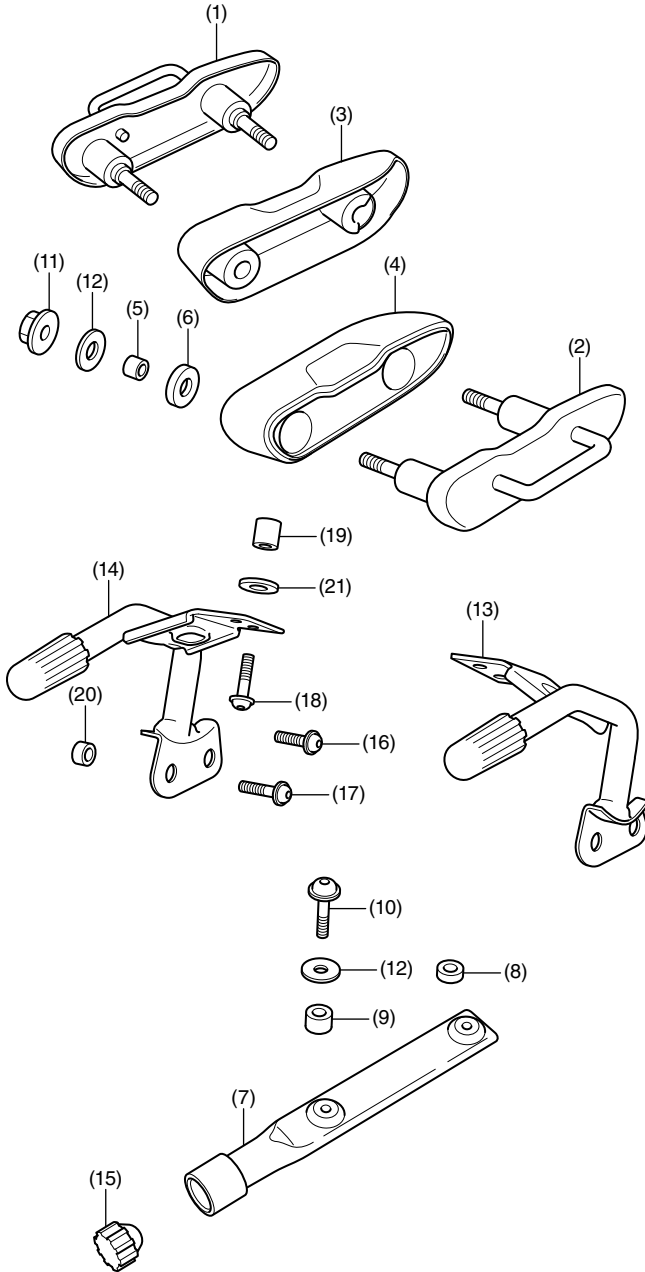

No.	Description	Qty
(1)	Right saddlebag hook	1
(2)	Left saddlebag hook	1
(3)	Right saddlebag hook cover	1
(4)	Left saddlebag hook cover	1
(5)	6 mm collar (thick)	4
(6)	6 mm collar (thin/large)	4
(7)	Saddlebag bracket	2
(8)	6 mm collar (thin/small)	2
(9)	6 mm collar (medium)	2
(10)	6 mm socket bolt	4
(11)	6 mm flange nut	4
(12)	Washer (small)	8
(13)	Right saddlebag support stay	1
(14)	Left saddlebag support stay	1
(15)	Rubber stop	2
(16)	8 mm socket bolt (short)	2
(17)	8 mm socket bolt (medium)	2
(18)	8 mm socket bolt (long)	4
(19)	8 mm collar (long)	4
(20)	8 mm collar (short)	2
(21)	Washer (large)	16

REAR CARRIER/SADDLEBAG MOUNT BRACKETS
(Sold separately)

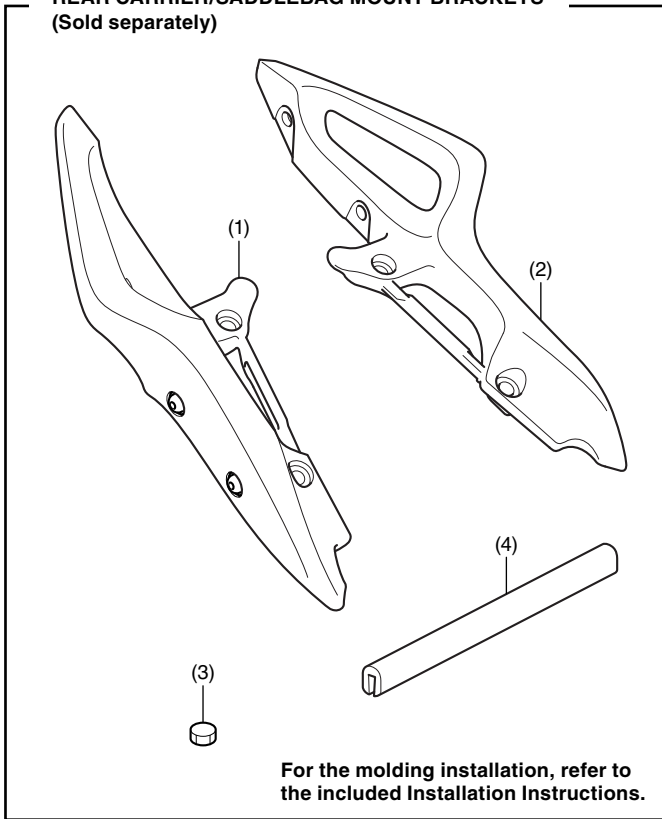

No.	Description	Qty
(1)	Right saddlebag bracket	1
(2)	Left saddlebag bracket	1
(3)	Plug	4
(4)	Molding	1

TOOLS AND SUPPLIES REQUIRED

- Box-end wrench (10 mm)
- Hex wrench (4 and 5 mm)
- Electric drill
- Hole saw (20 mm)
- File
- Fret saw
- Scissors
- Ruler
- Wood block 10 mm thick
- Marker
- Tape
- Electrical tape
- Isopropyl alcohol
- Shop towel
- Torque wrench

TORQUE CHART

Tighten all screws, bolts, and nuts to their specified torque values. Refer to the Service Manual for the torque values of the removed parts.

Item	N·m	kgf·m	lbf·ft
6 mm socket bolt	10	1.0	7
6 mm flange nut	12	1.2	9
8 mm socket bolt	22	2.2	16
Motorcycle's 8 mm socket bolt	30	3.1	22

USE AND CARE INFORMATION

- Check the accessory mounts frequently and retighten if necessary.

INSTALLATION INFORMATION

CAUTION:

- To prevent burns, allow the engine, exhaust system, radiator, etc. to cool before installing accessory.

NOTE:

- The rear carrier/saddlebag brackets which are sold separately are required to install this accessory.
- Take care not to damage the painted surfaces of the motorcycle.
- When the motorcycle is already equipped with the Rear Carrier, remove the Rear carrier and Rear Carrier/Saddlebag Brackets before installing this accessory.

INSTALLATION

1. Refer to the Service Manual for the motorcycle, remove the motorcycle parts as shown.

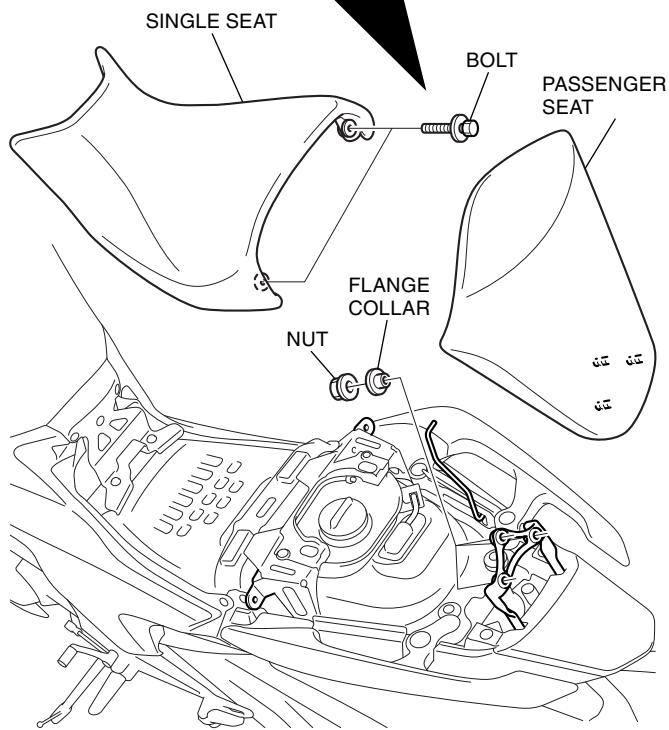
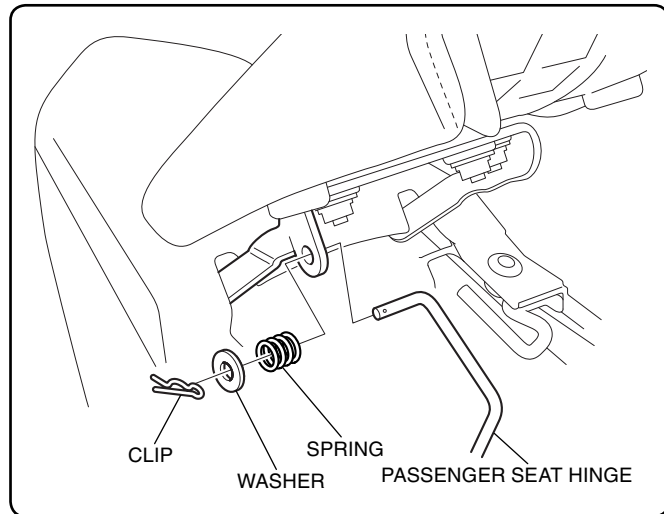

2. Refer to the Service Manual for the motorcycle, remove the drive chain case.

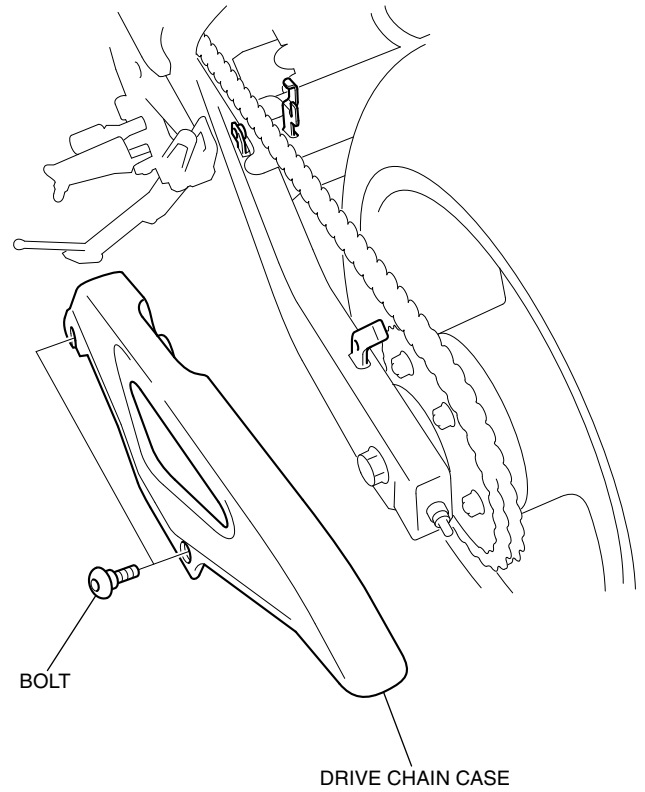

3. Refer to the Service Manual for the motorcycle, remove the right and left grab rails.

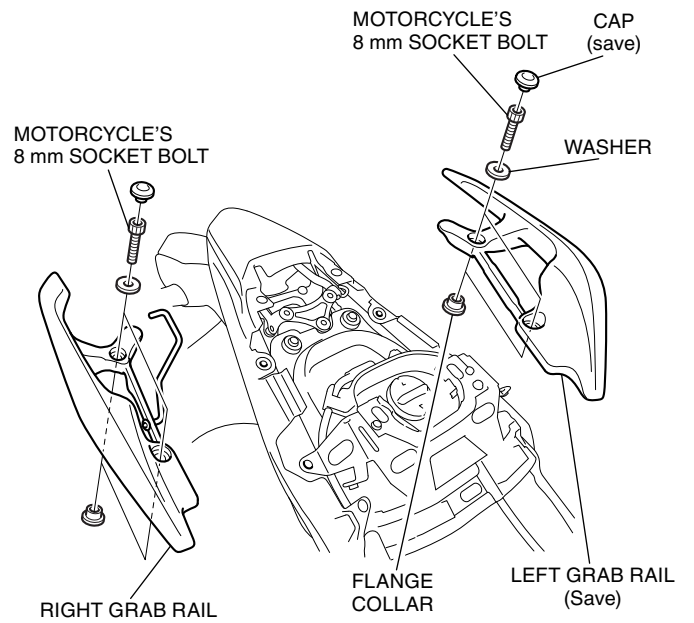

4. Remove the passenger seat hinge as shown.

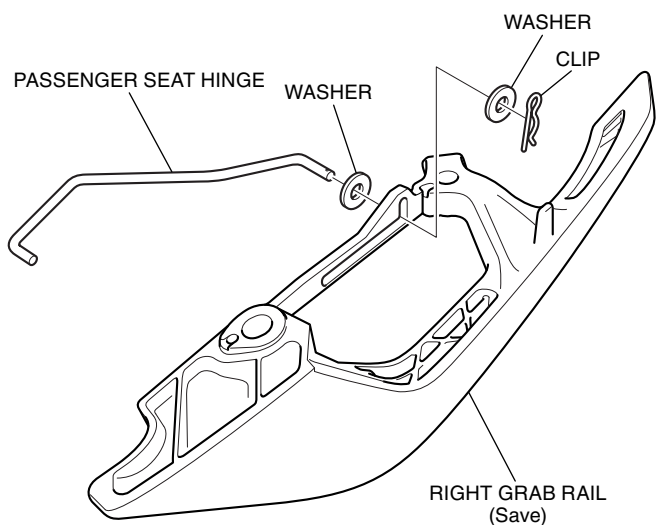

5. Refer to the Service Manual for the motorcycle, remove the seat cowl.

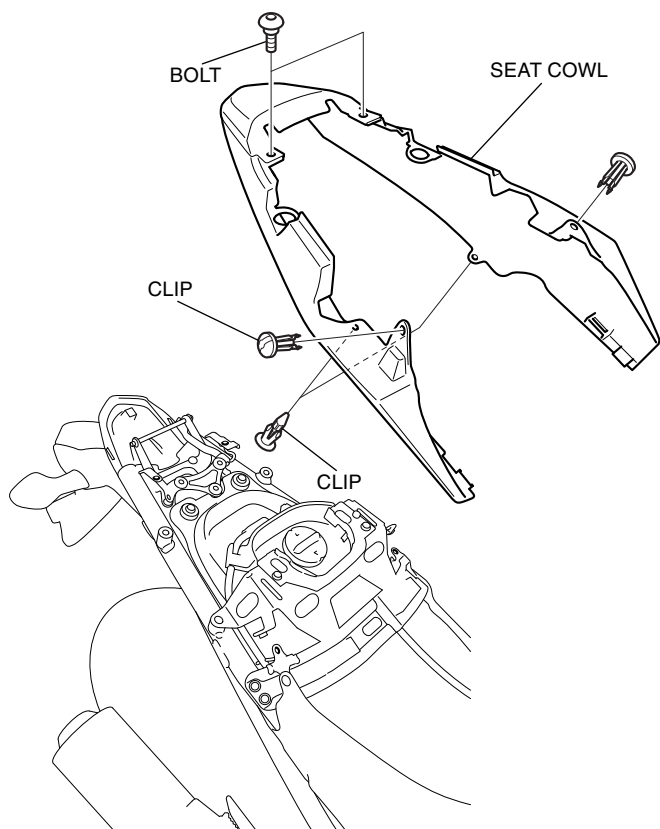

6. Cut and attach the template to the seat cowl and mark it using a marker as shown.

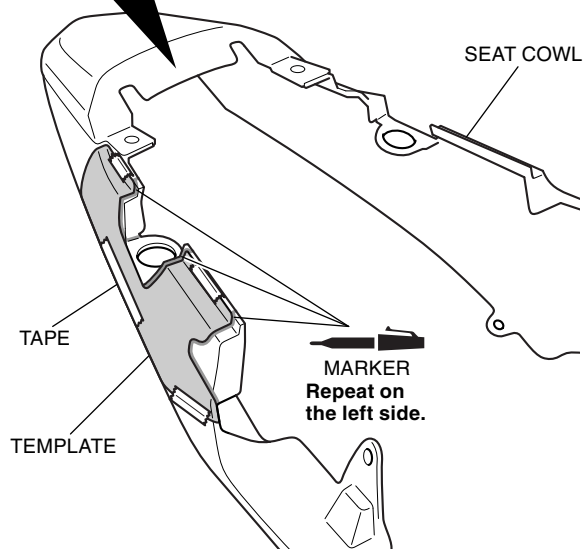
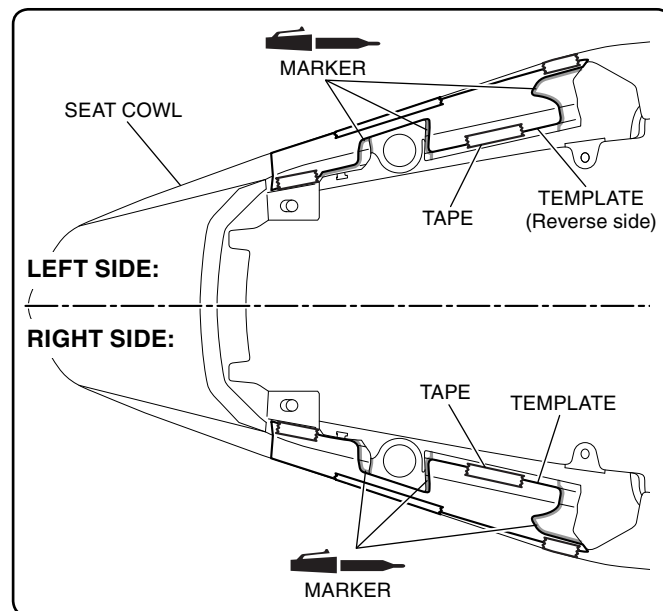

7. Remove the template. Cut out the shaded areas on the seat cowl as shown.
- Repeat on the left side.

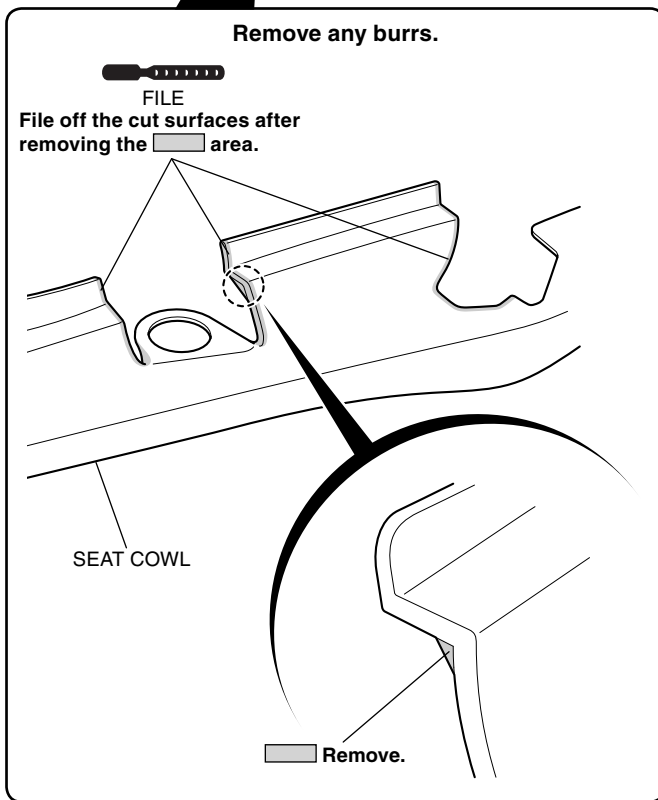
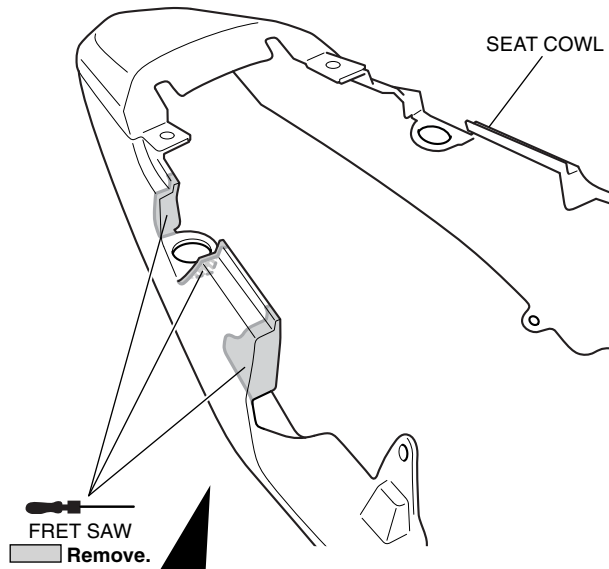

8. Install the seat cowl in the reverse order of removal.

<If rear fender B has factory marked points>

9. Drill 20 mm holes at the factory marked points on the rear fender B using an electric drill and hole saw.
- Be careful not to damage harnesses.
 - Remove any burrs from the edge of the hole.
 - Repeat on the left side.

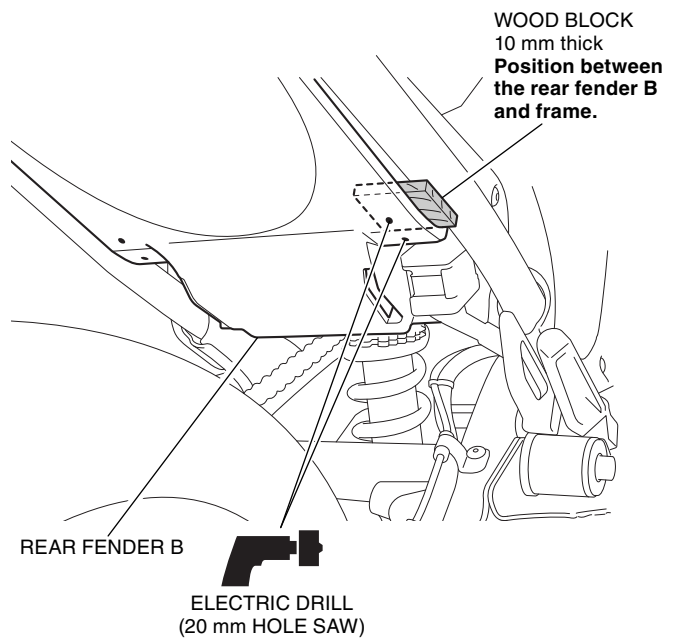
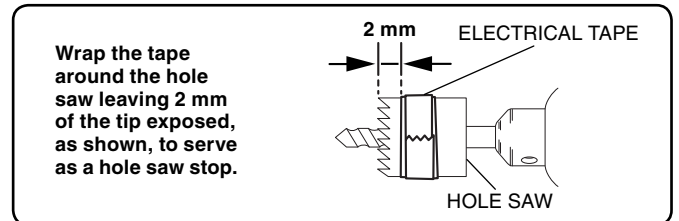

<If rear fender B has slits>

9. Work upon the rear fender B as shown.
- Be careful not to damage harnesses.
 - Remove any burrs from the edge of the hole.
 - Repeat on the left side.

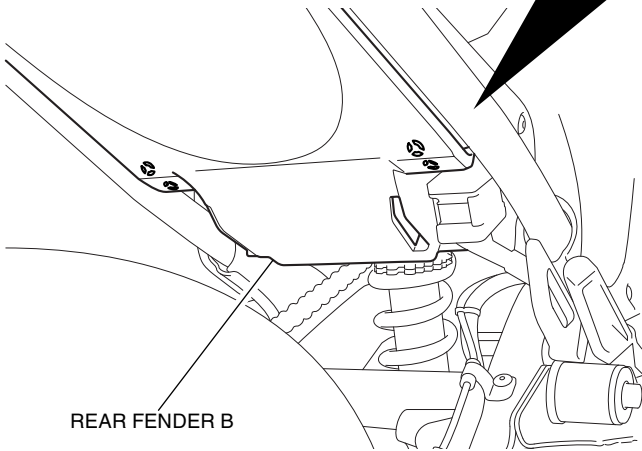
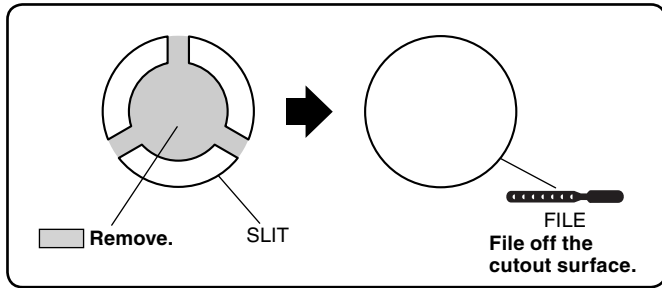

10. Remove the bolts and nuts as shown.
- Repeat on the left side.

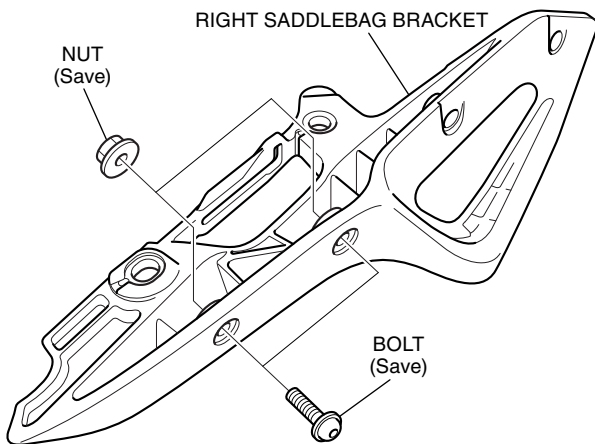

11. Install the right saddlebag hook cover and hook as shown.
- Repeat on the left side.

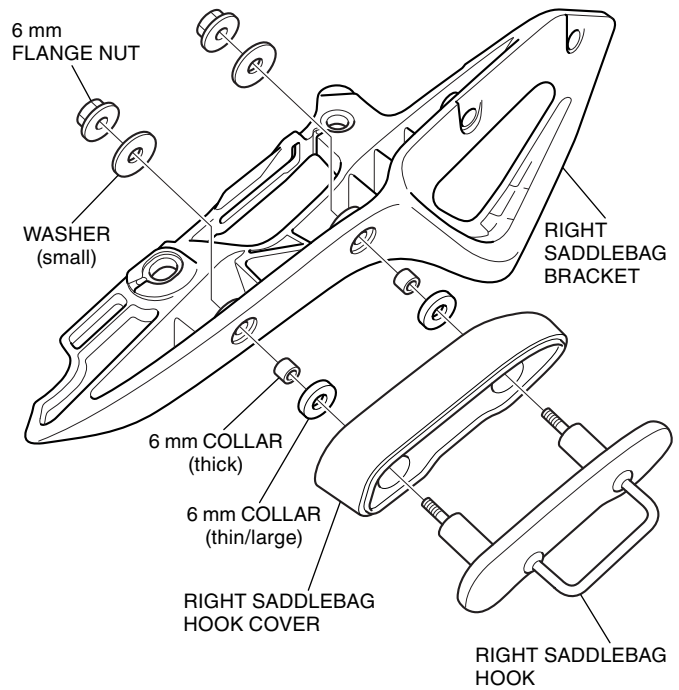

12. Install the passenger seat hinge as shown.

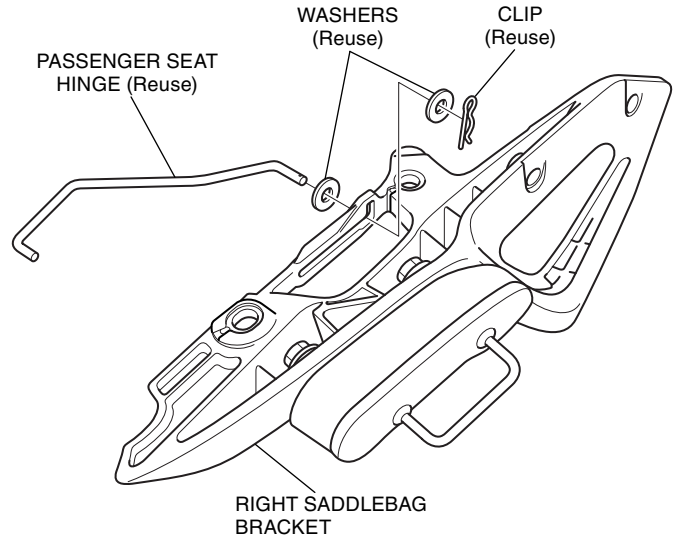

13. Loosely install the saddlebag stays as shown.

- **Do not install the plugs yet.**

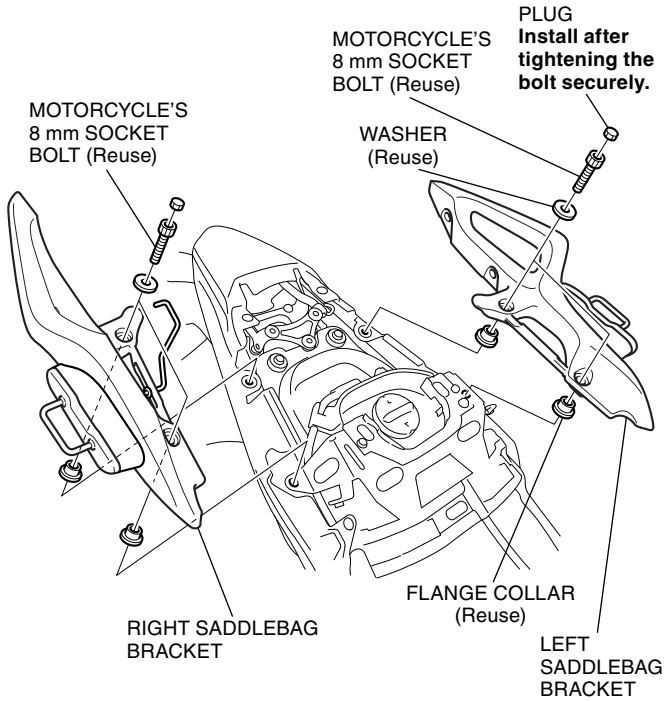

14. Loosely install the right saddlebag support stay as shown.

- **Repeat on the left side.**

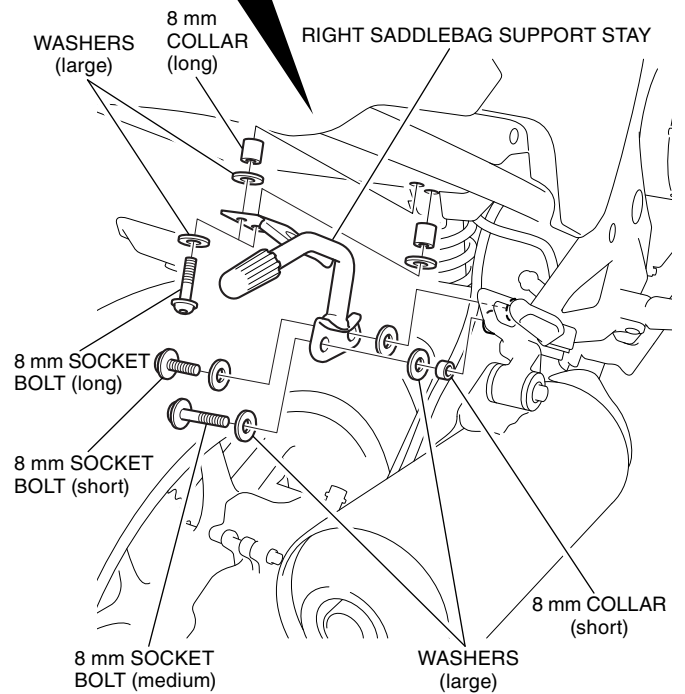
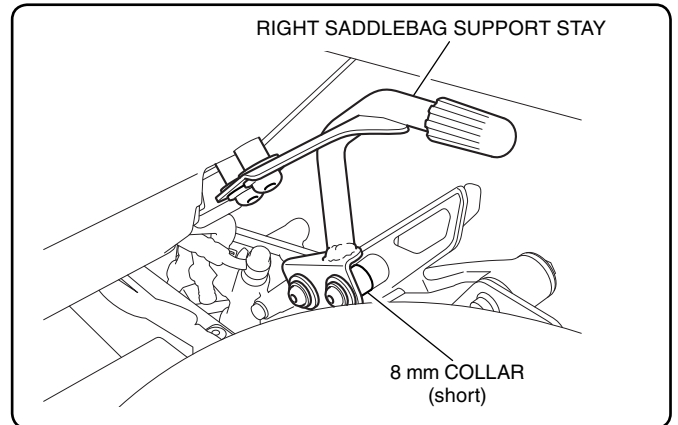

15. Install the rubber stop as shown.

- **Make up both brackets.**

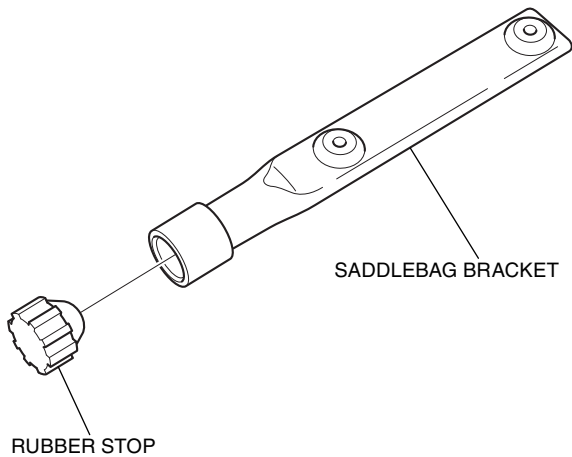
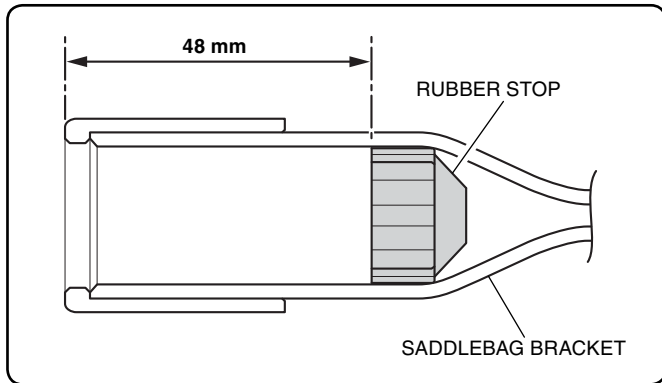

16. Install the saddlebag bracket as shown.

- **Repeat on the left side.**

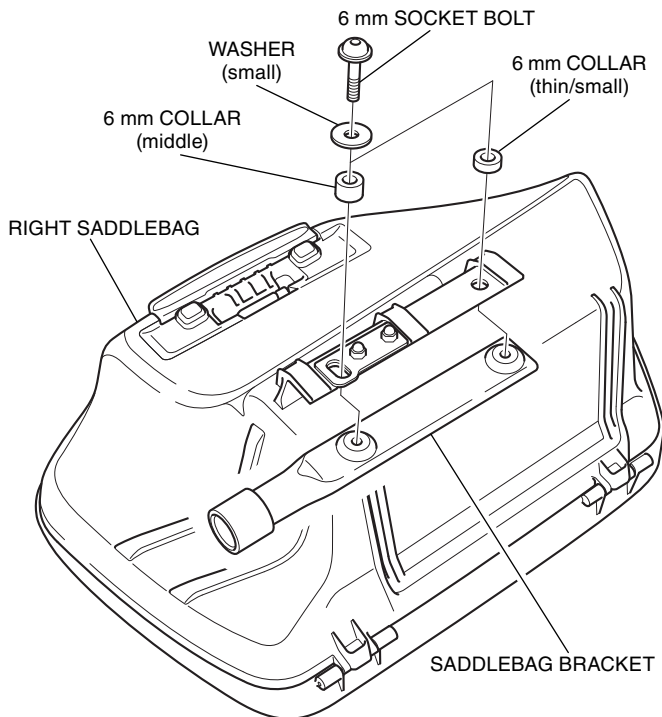

17. Install the right saddlebag and tighten all loosely installed hardware to the specifications in the torque chart.

- **When securing the saddlebag support stay, first tighten the upper bolts.**
- **Repeat on the left side.**

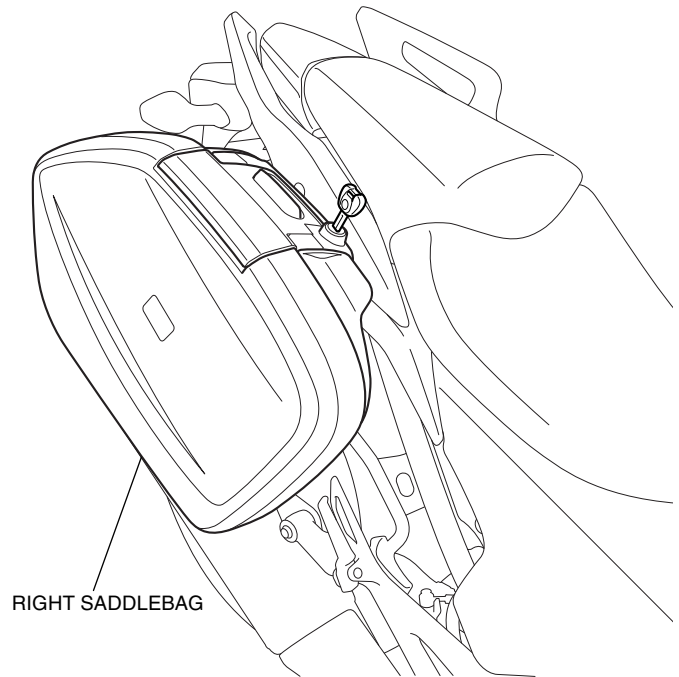
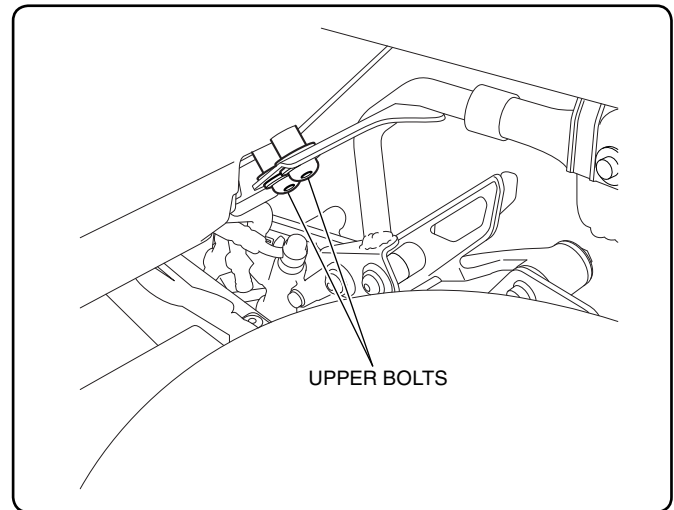

18. Install the removed parts in the reverse order of removal.

<TEMPLATE>

Cut off along the dotted line.

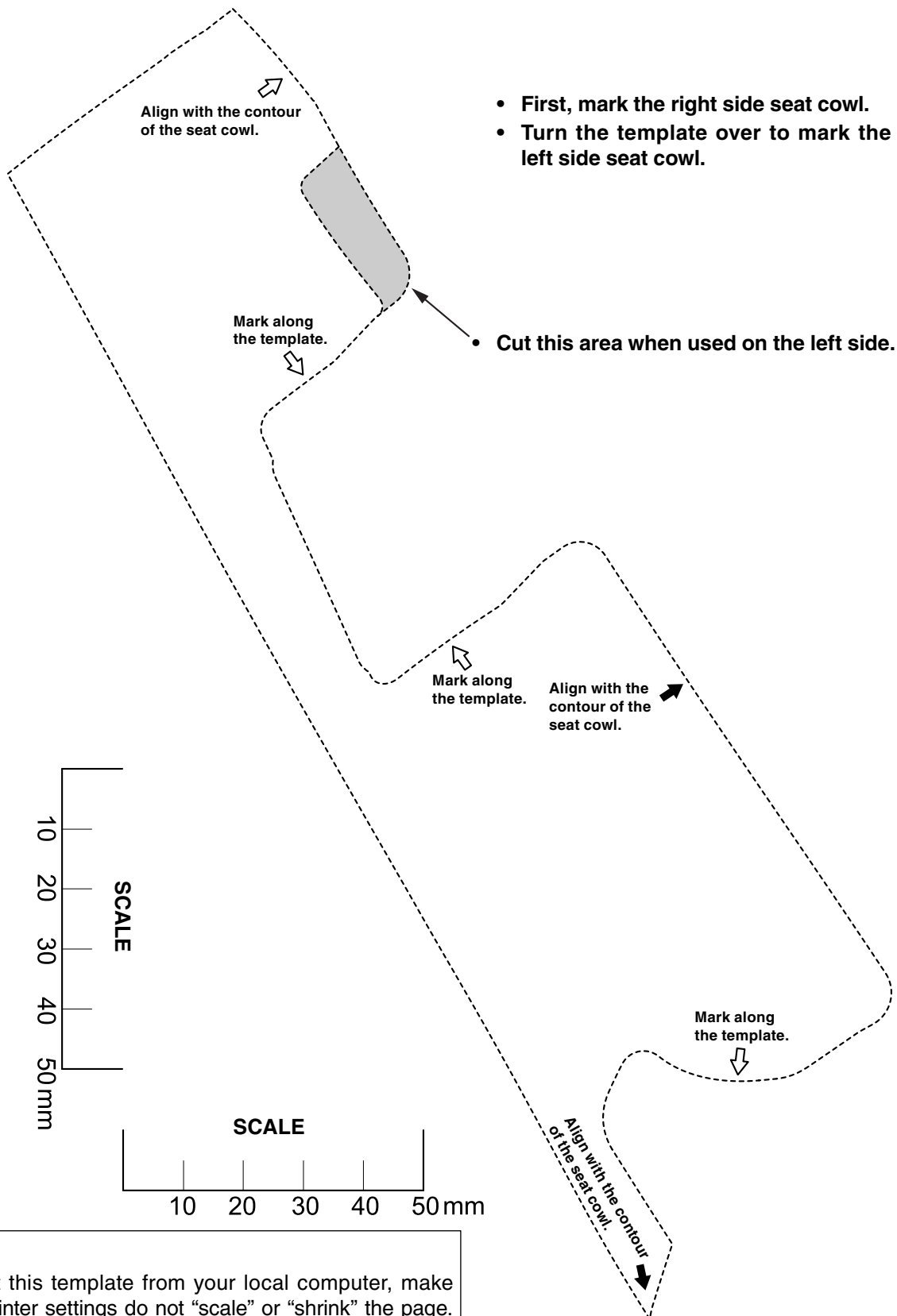

NOTICE

If you print this template from your local computer, make sure the printer settings do not “scale” or “shrink” the page.