



# INSTALLATION INSTRUCTIONS

Accessory

REAR CARRIER  
P/N 08L72-MGS-A30

Application

2012  
NC700X/XD

Publication No.

MII 13973-14449

Issue Date

Revised:

February 2013

**Honda Dealer: Please give a copy of these instructions to your customer.**

## PARTS LIST

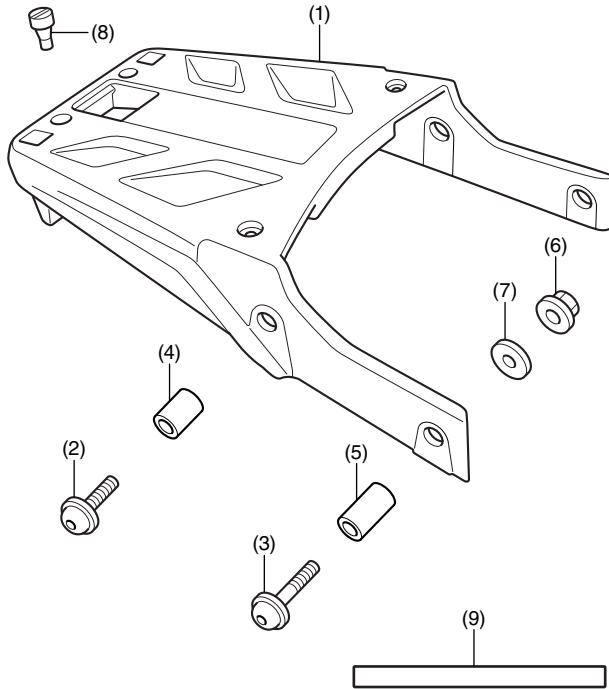

No.	Description	Qty
(1)	Rear carrier	1
(2)	8 mm socket bolt (short)	2
(3)	8 mm socket bolt (long)	2
(4)	Collar (short)	2
(5)	Collar (long)	2
(6)	8 mm flange nut	4
(7)	Washer	4
(8)	Cushion	4
(9)	Safety label	1

## REAR CARRIER/SADDLEBAG MOUNT BRACKETS (Sold separately)

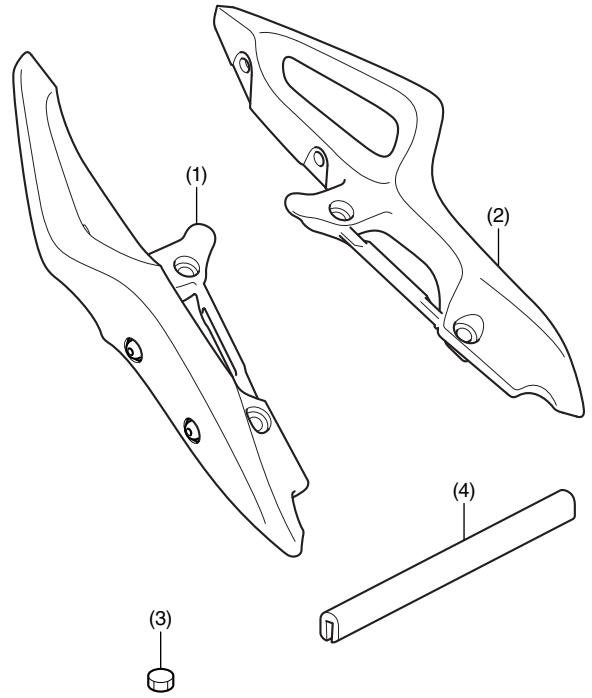

For the molding installation, refer to the included Installation Instructions.

No.	Description	Qty
(1)	Right saddlebag bracket	1
(2)	Left saddlebag bracket	1
(3)	Plug	4
(4)	Molding	1

## TOOLS AND SUPPLIES REQUIRED

Box-end wrench (12 mm)

Hex wrench (5 mm)

File

Fret saw

Scissors

Ruler

Marker

Tape

Isopropyl alcohol

Shop towel

Torque wrench

## TORQUE CHART

Tighten all screws, bolts, and nuts to their specified torque values. Refer to the Service Manual for the torque values of the removed parts.

Item	N·m	kgf·m	lbf·ft
8 mm flange nut	27	2.8	20
Motorcycle's 8 mm socket bolt	30	3.1	22

## USE AND CARE INFORMATION

- The weight of the cargo must not exceed the following maximum weight capacity:

Maximum Weight Capacity	
Rear carrier	22 lb (10 kg)

- Check the accessory mounts frequently and retighten if necessary.

## INSTALLATION INFORMATION

### NOTE:

- The Rear Carrier/Saddlebag Brackets which are sold separately are required to install this accessory.
- Heat the bonding surfaces with a hair dryer if the ambient air temperature is below 70°F (21°C).
- The adhesive reaches full strength in 72 hours. Wait at least 24 hours before riding your motorcycle.
- Take care not to damage the painted surfaces of the motorcycle.
- When the motorcycle is already equipped with the Rear Carrier/Saddlebag Brackets, loosen all its mounting bolts before installing this accessory.

## INSTALLATION

- Refer to the Service Manual for the motorcycle, remove the seats.

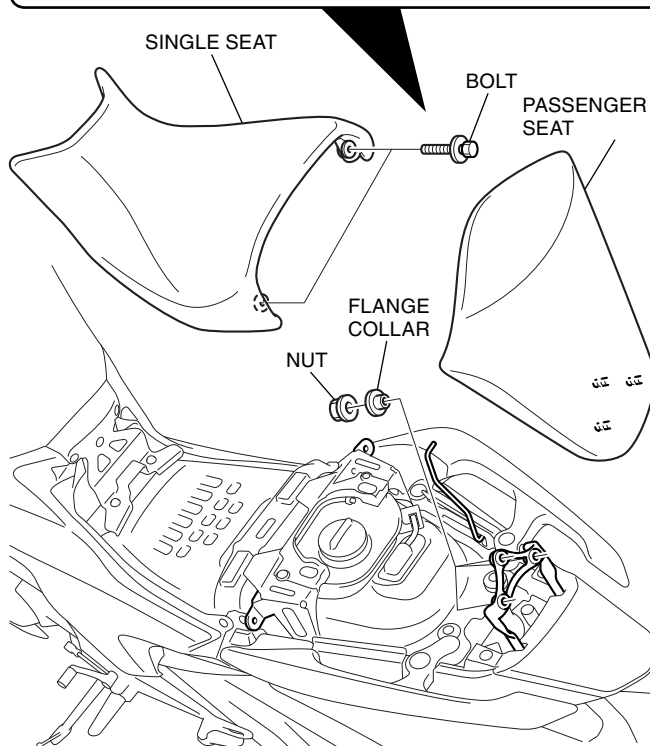
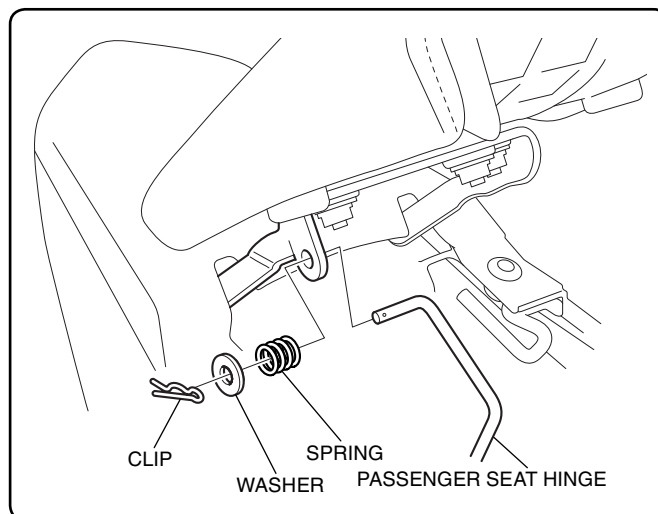

2. Refer to the Service Manual for the motorcycle, remove the right and left grab rails.

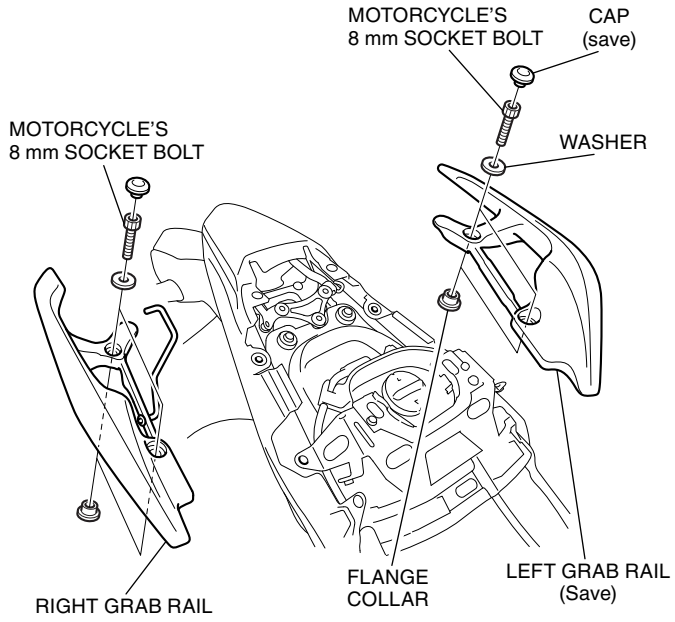

3. Remove the passenger seat hinge as shown.

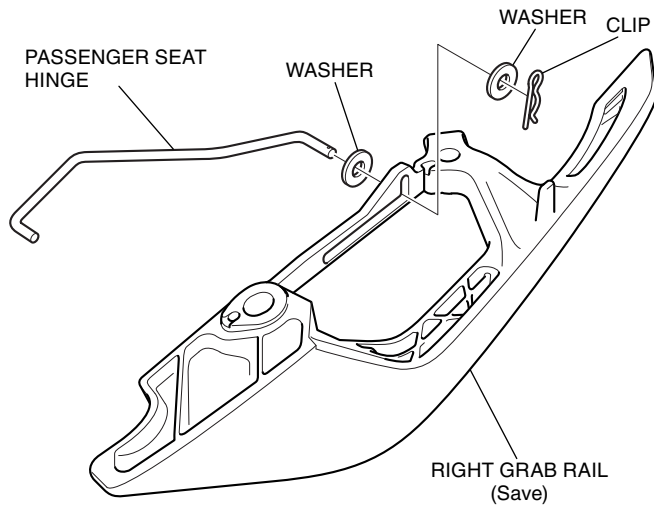

4. Refer to the Service Manual for the motorcycle, remove the seat cowl.

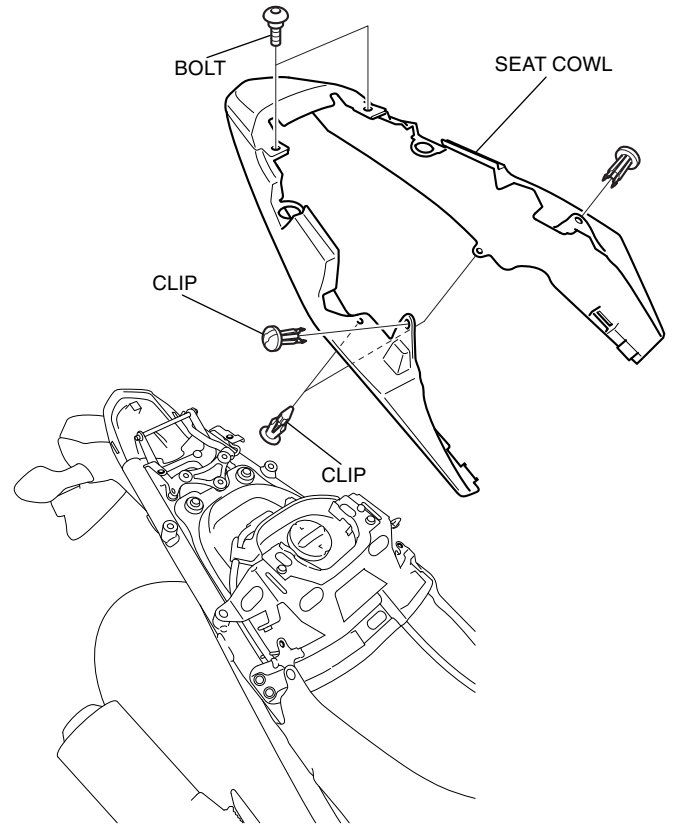

5. Cut and attach the template to the seat cowl and mark it using a marker as shown.

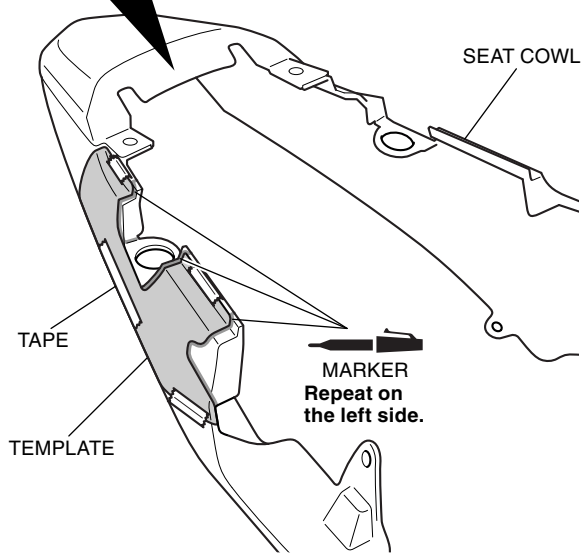
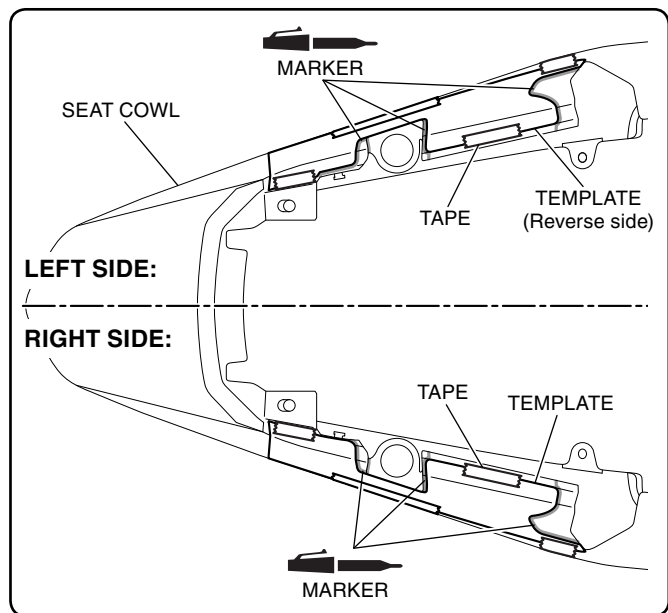

6. Remove the template. Cut out the shaded areas on the seat cowl as shown.

- Repeat on the left side.

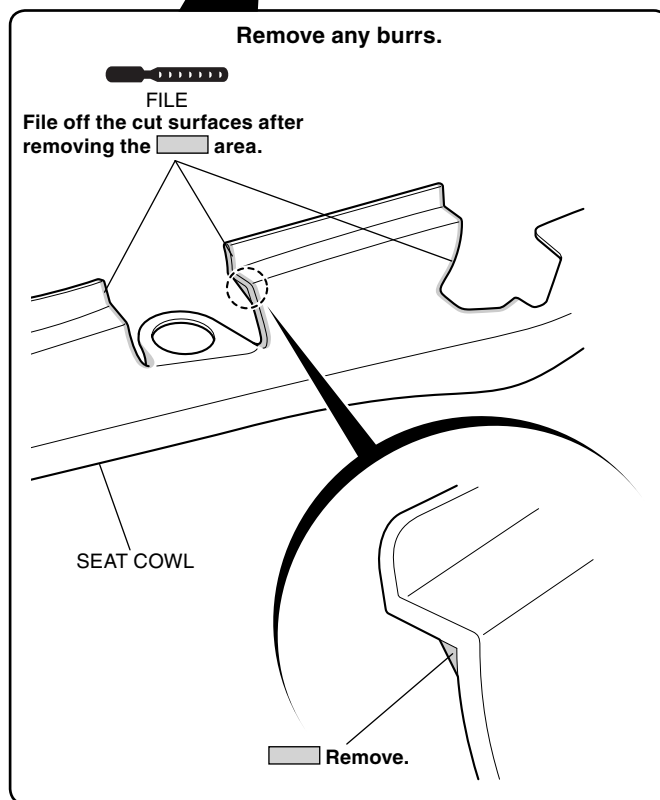
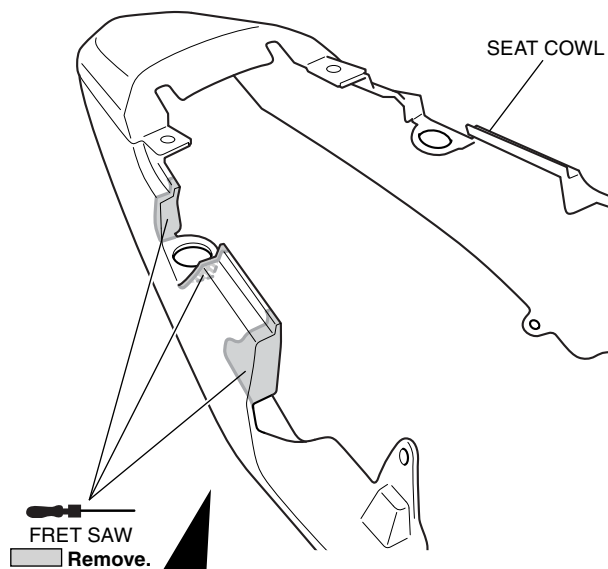

7. Install the seat cowl in the reverse order of removal.

8. Install the passenger seat hinge as shown.

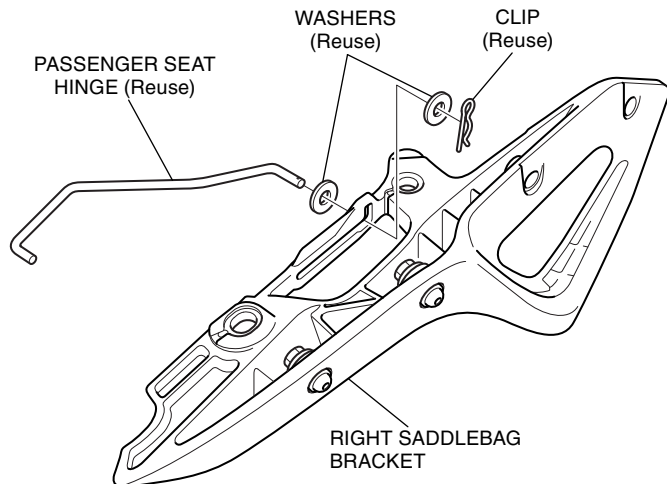

9. Loosely install the saddlebag brackets as shown.  
 • Do not install the plugs yet.

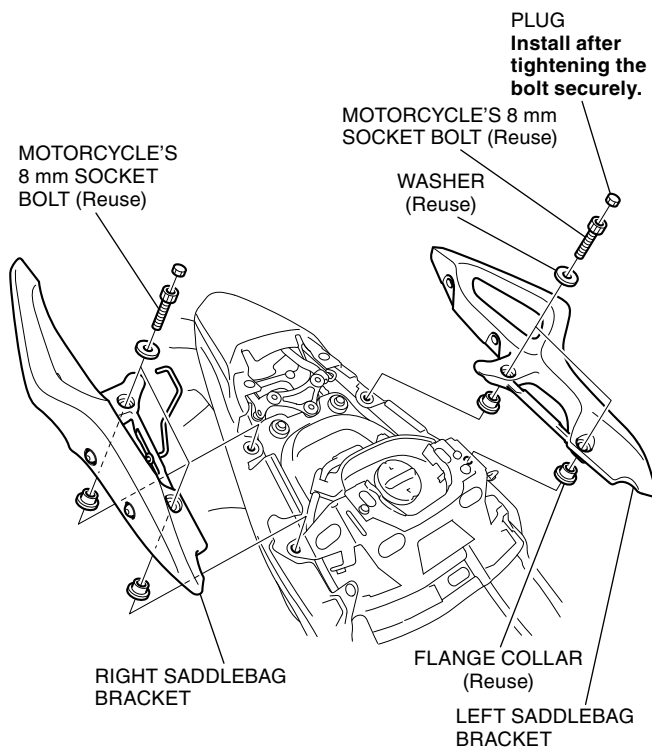

10. Loosely install the rear carrier as shown.

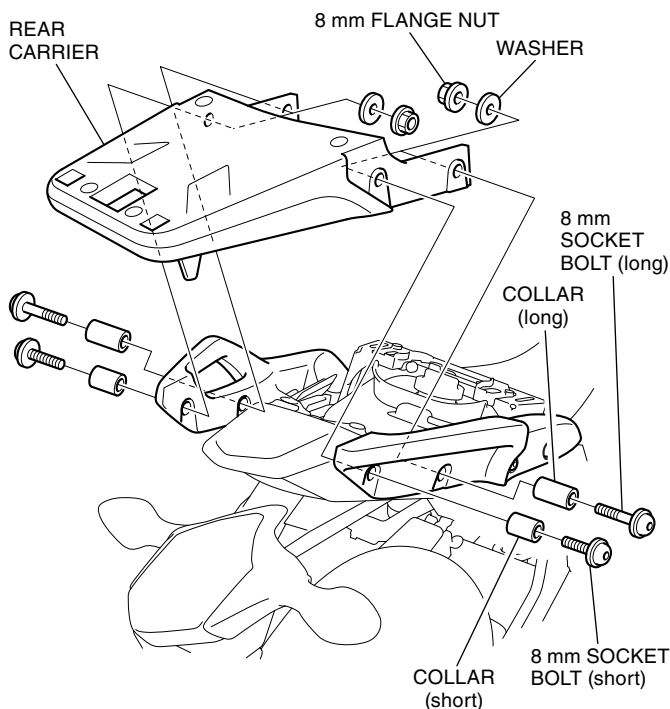

11. Tighten all loosely installed hardware to the specifications in the torque chart.

12. Install the removed parts in the reverse order of removal.

13. Install the cushions at the positions shown.

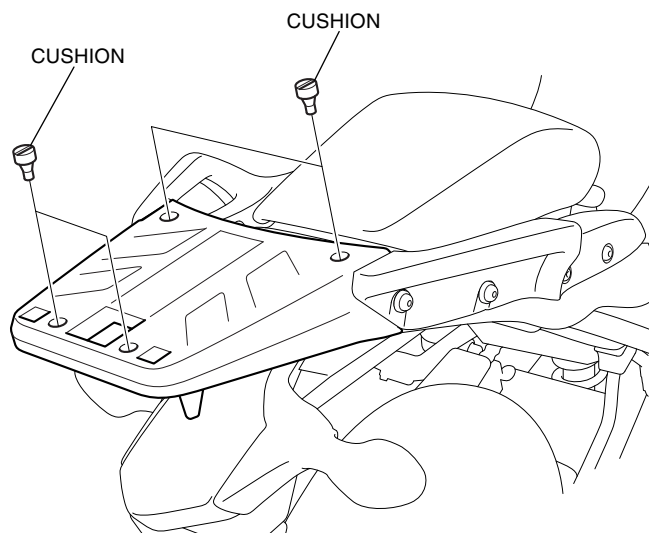

14. Attach the safety label in the position shown.

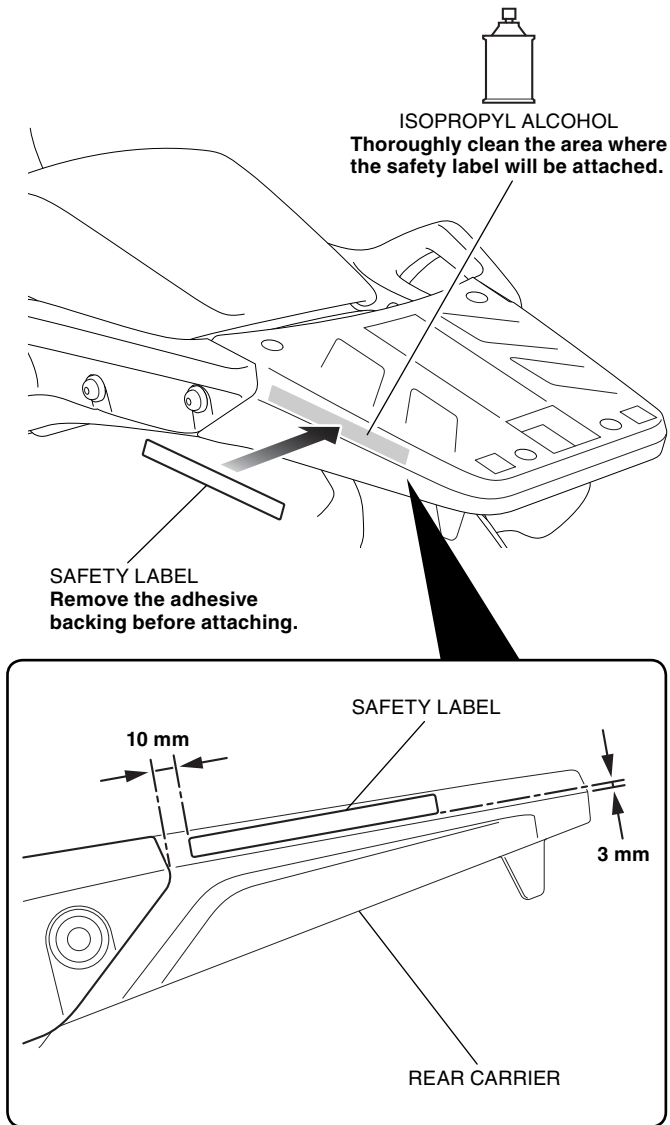

# <TEMPLATE>

Cut off along the dotted line.

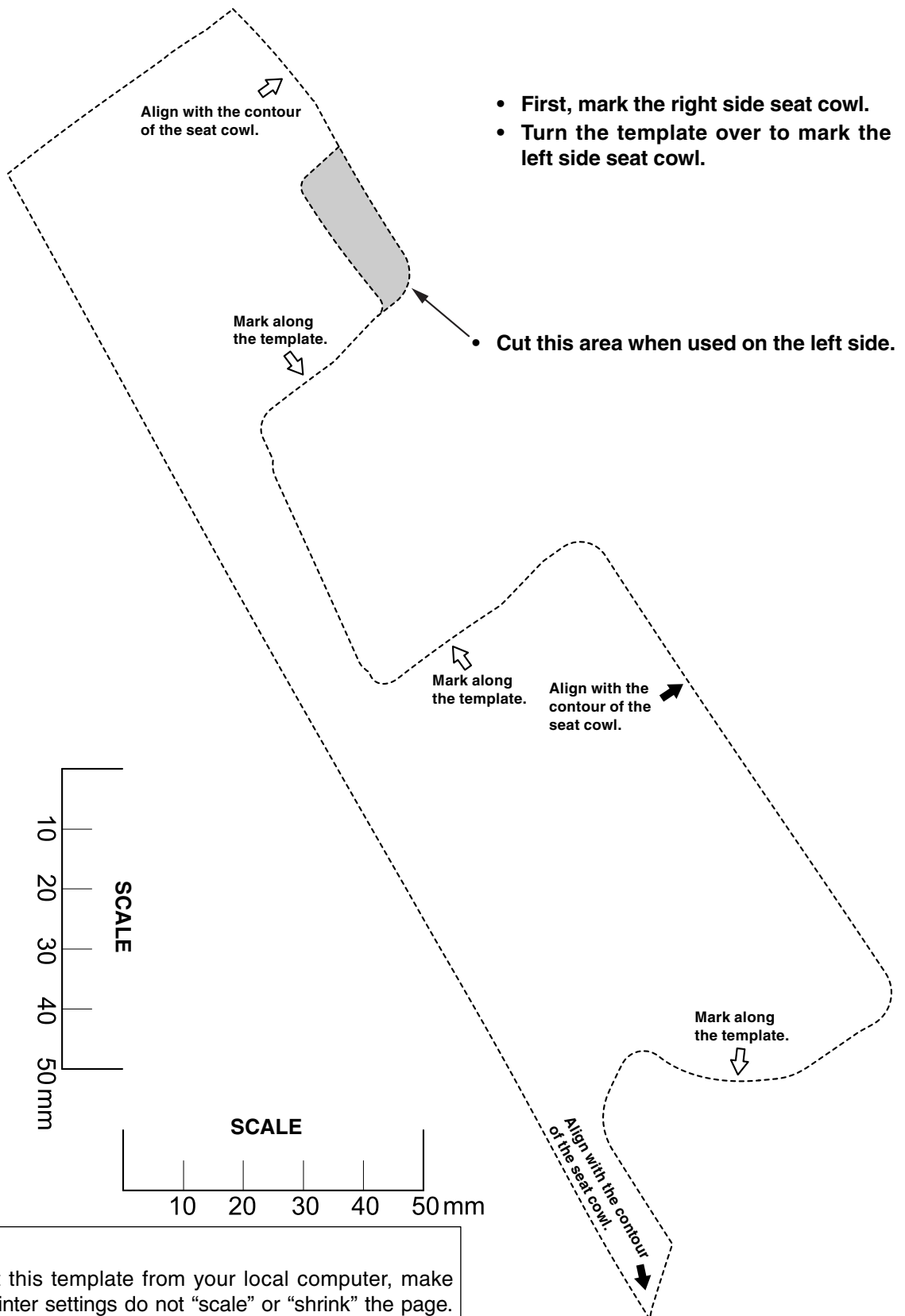

## NOTICE

If you print this template from your local computer, make sure the printer settings do not “scale” or “shrink” the page.