

Honda Dealer: Please give a copy of these instructions to your customer.

PARTS LIST

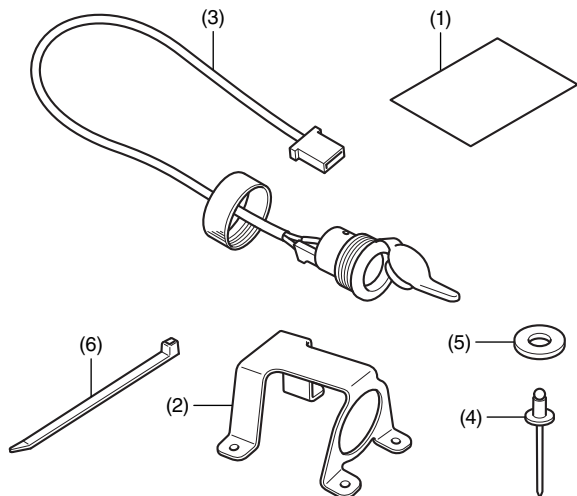

No.	Description	Qty
(1)	Installation Instruction URL paper	1
(2)	Bracket	1
(3)	Socket assy.	1
(4)	Rivet	4
(5)	3 mm washer	4
(6)	Wire tie	3

SUB HARNESS Sold separately

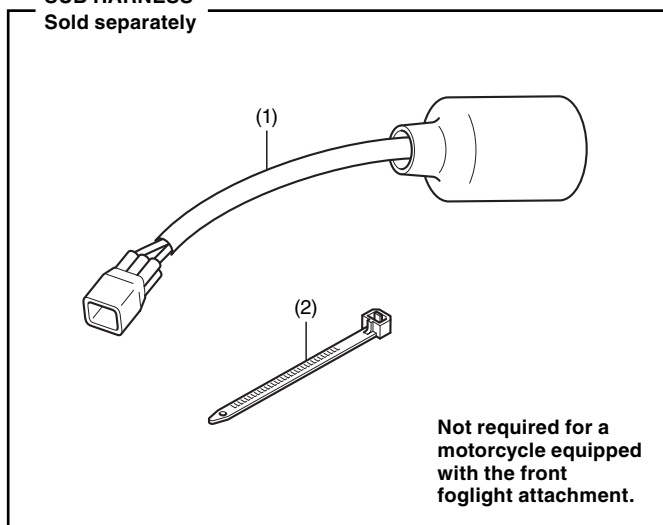

No.	Description	Qty
(1)	Subharness	1
(2)	Wire tie	3

TOOLS AND SUPPLY REQUIRED

- Side cutters
- Electric drill
- Drill bit (3.5 mm)
- Electrical tape
- Riveter
- Silicone caulk

TORQUE INFORMATION

Refer to the Service Manual for the torque values of the removed parts.

Please Convey the Following Information to the Customer During Delivery

NOTICE:

- **This Accessory Socket is rated for a maximum current of up to 3amps.**
- **Switch off or disconnect accessories when the engine is stopped to avoid discharging the battery.**

INSTALLATION

▲ CAUTION

- To prevent burns, allow the engine, exhaust system, radiator, etc. to cool before installing the accessory.

NOTE:

- Take care not to damage the painted surfaces of the motorcycle.
- Reinstall the removed parts on the motorcycle and make sure that wires and harnesses are not pinched.
- Disconnect the negative (-) cable from the battery before installing this accessory.
- The memories of the tripmeter, and clock will be erased when you disconnect the battery. After reconnecting the battery, refer to the motorcycle Owner's Manual and reset the clock.
- Trim the excess ends off the wire ties after attaching them to the wire harnesses. Do not allow the cut part of the wire tie to interfere with another harness or brake hose.
- After this accessory installation, check the lights (e.g. right / left turn signal lights and brake lights) for proper operation.
- When replacing any other accessory that is required to install this accessory, follow these instructions only.

1. Refer to the Service Manual to remove the following parts. Disconnect the negative (-) cable from the battery.

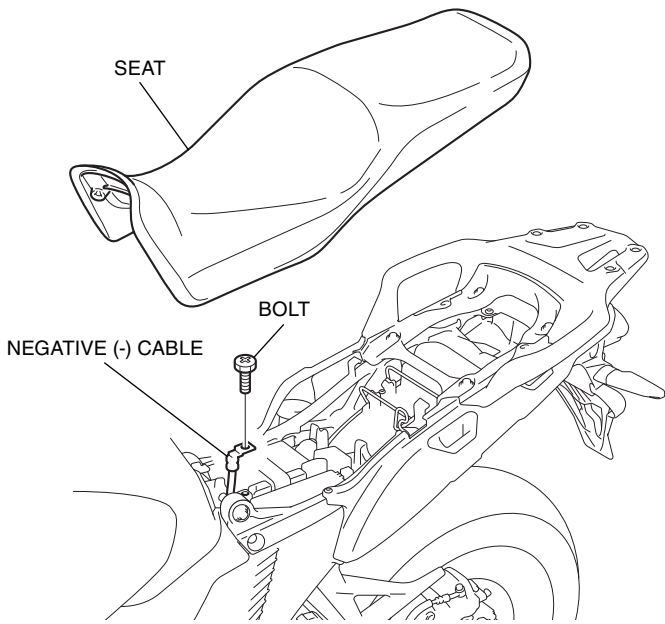

2. Disconnect the positive battery cable, and remove the battery.

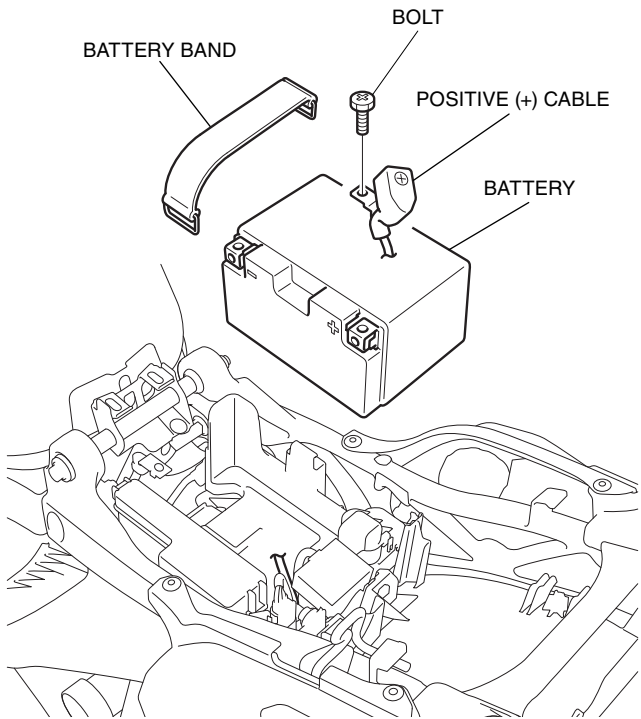

3. Remove the following clips and bolts in the order described then remove the left middle cowl. Disconnect the connector.
 - Repeat on the right side.

<Left side>

LEFT MIDDLE COWL
Do not remove yet.

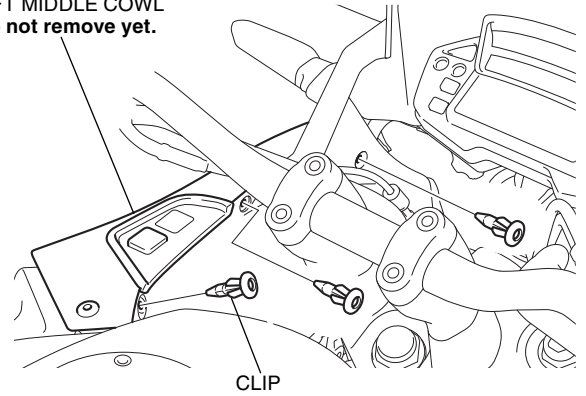

LEFT MIDDLE COWL
Do not remove yet.

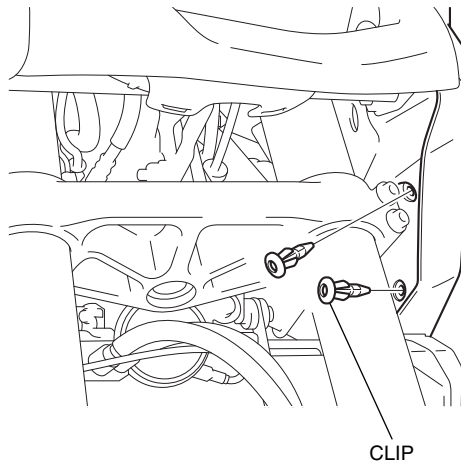

LEFT MIDDLE COWL
Do not remove yet.

BOLT

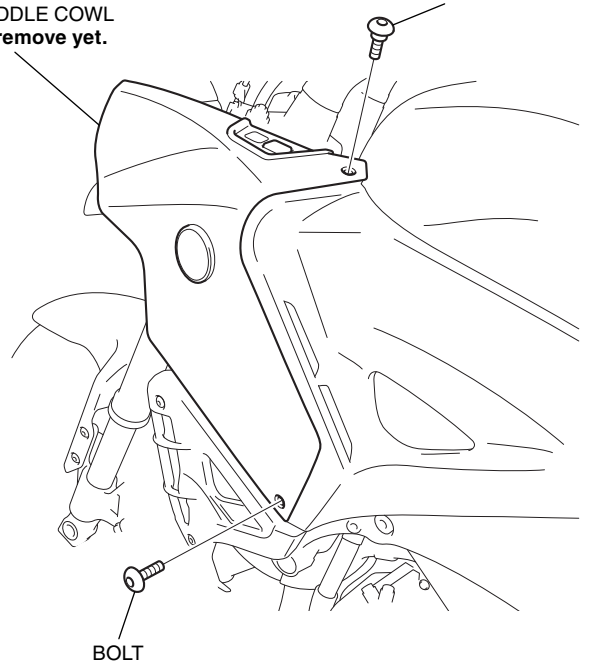

2-PIN WATERPROOF CONNECTOR (Blue)
Disconnect.

LEFT MIDDLE COWL
Remove.

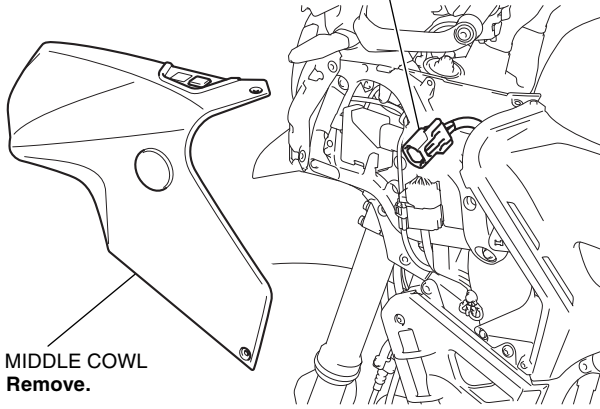

When the Front Foglight Attachment (Sold separately) is installed, disconnect the foglight switch connector as shown.

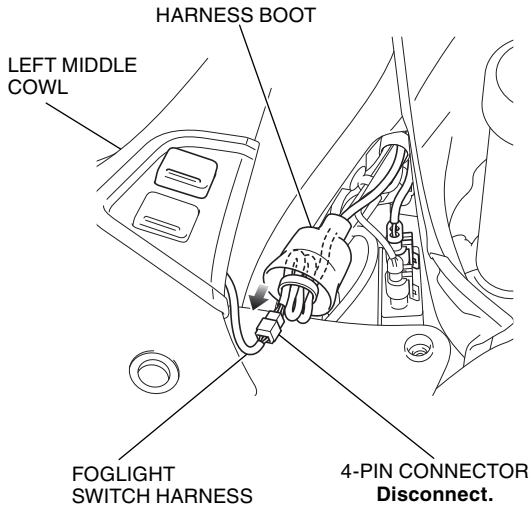

4. Remove the left knee cowl.
• Repeat on the right side.

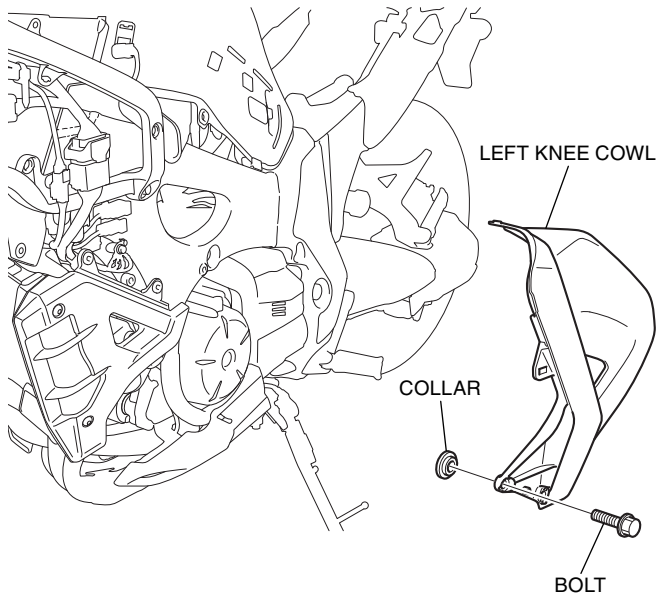

5. Remove the dummy connector as shown.

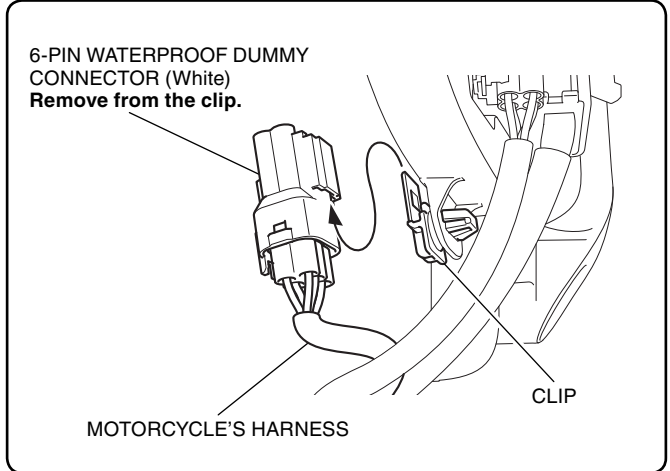
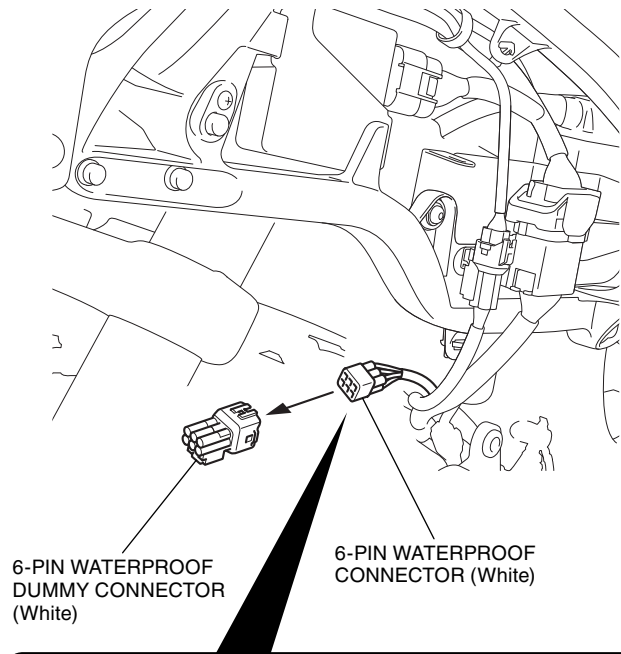

6. Route and connect the subharness as shown.

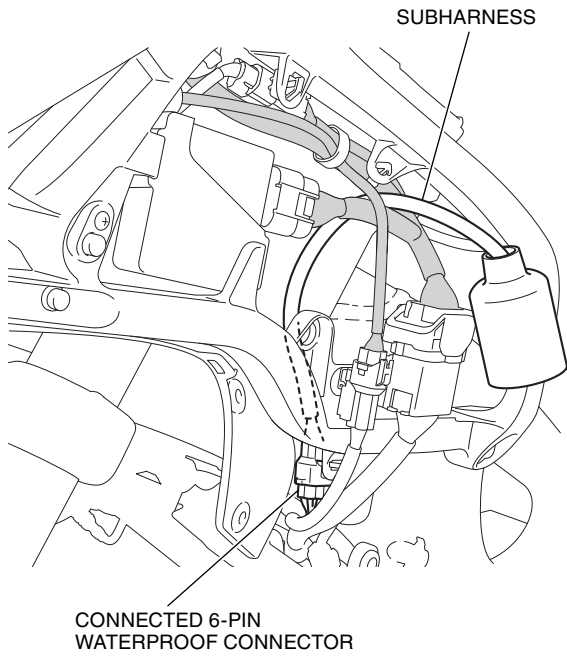

7. Secure the subharness with the wire tie as shown.

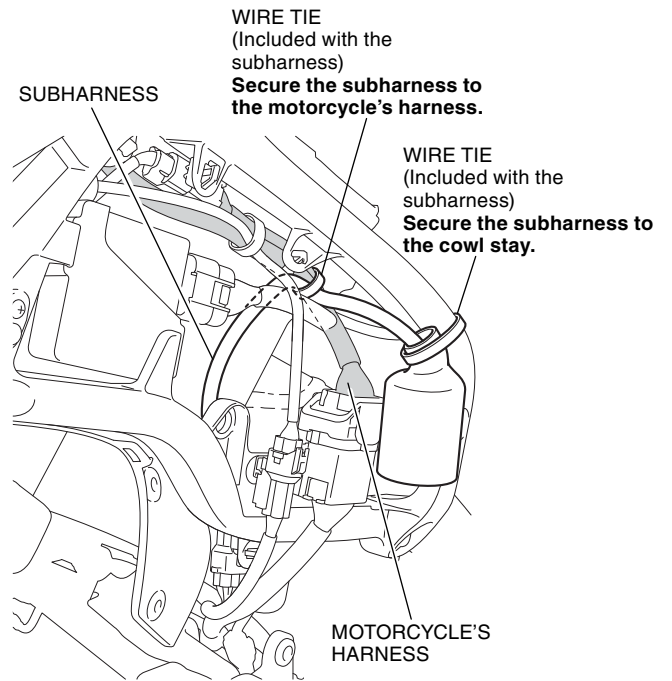

Connect the subharness and secure it to the clip.

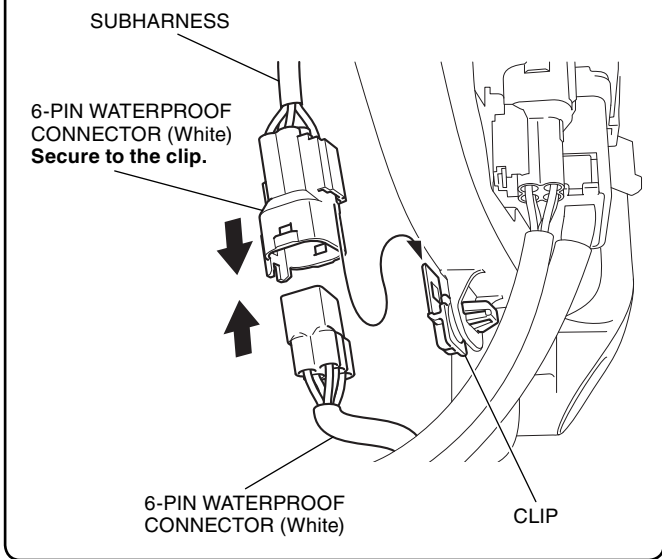

8. Drill at the marked points on the rear fender using an electric drill as shown.

- Remove any burrs from the edges of the holes.

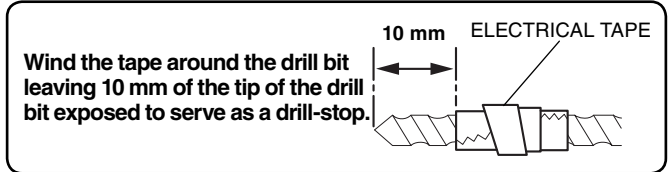

ELECTRIC DRILL
(3.5 mm BIT)

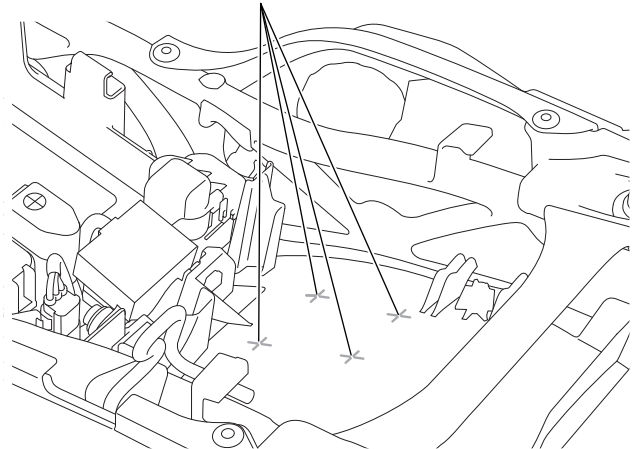

9. Assemble the accessory socket as shown.

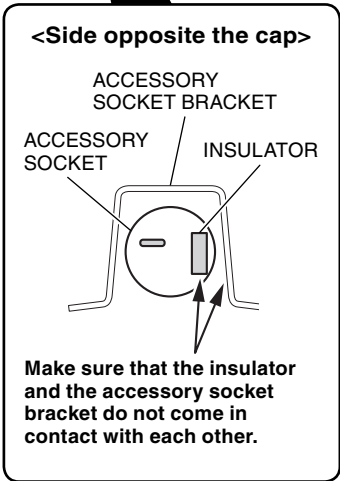
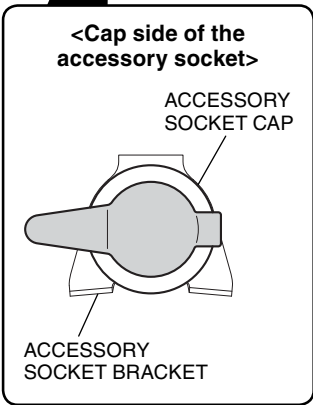
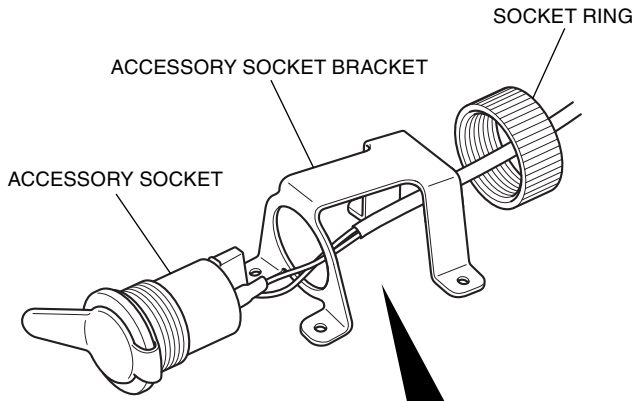

10. Install the assembled accessory socket as shown.

- Route the rubber band over the accessory socket assembly as shown.

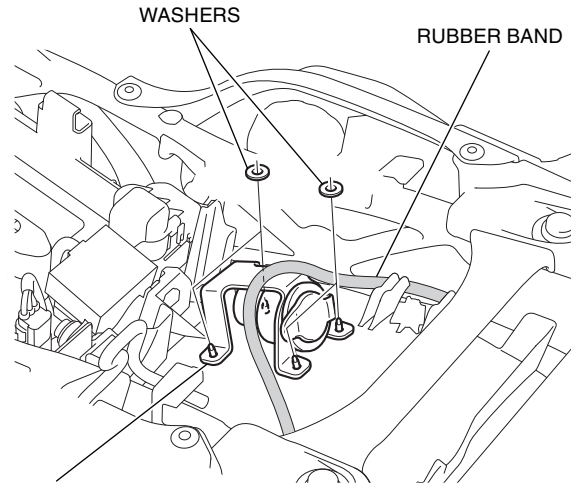
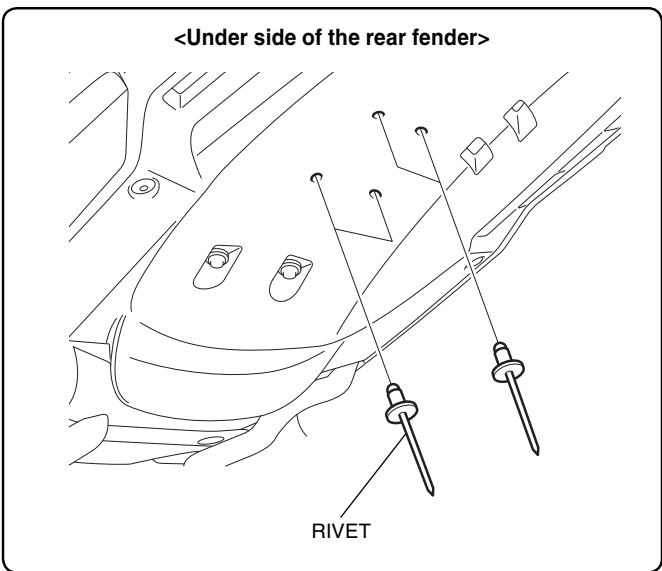

ACCESSORY SOCKET ASSEMBLY

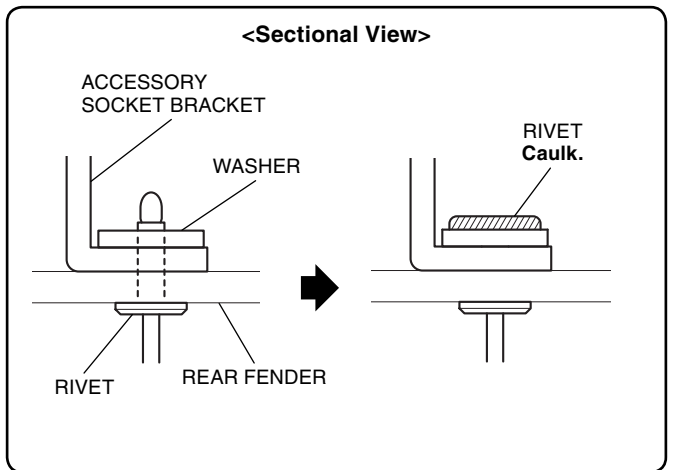

11. Remove the motorcycle parts as shown.

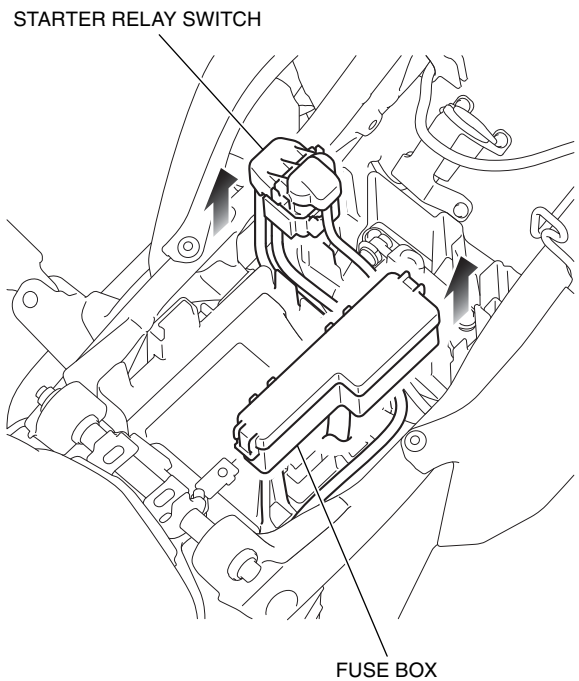

12. Route the socket harness as shown.

- After routing the socket harness, install the fuse box and starter relay switch in the original positions.

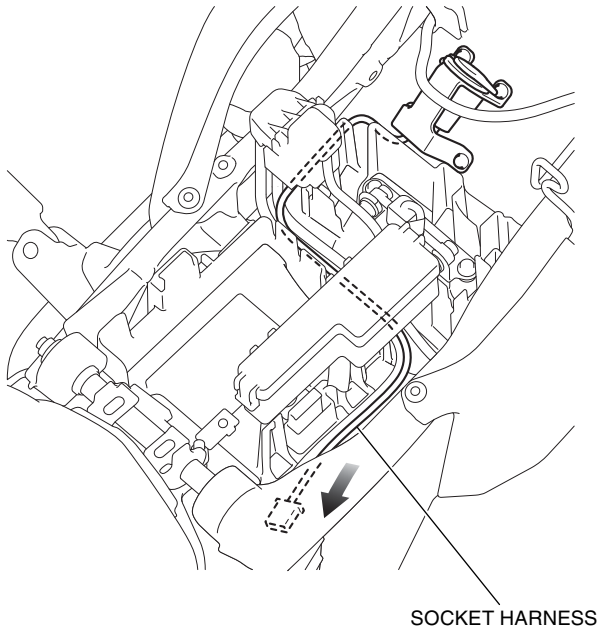

13. Lift the fuel tank up as shown.

- Hold the lifted fuel tank securely.

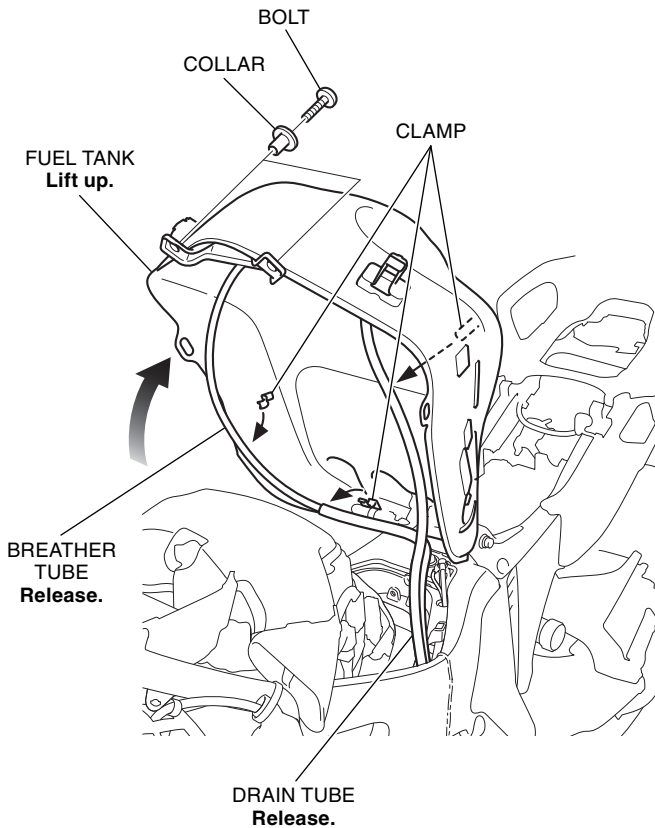

14. Remove the protector as shown.

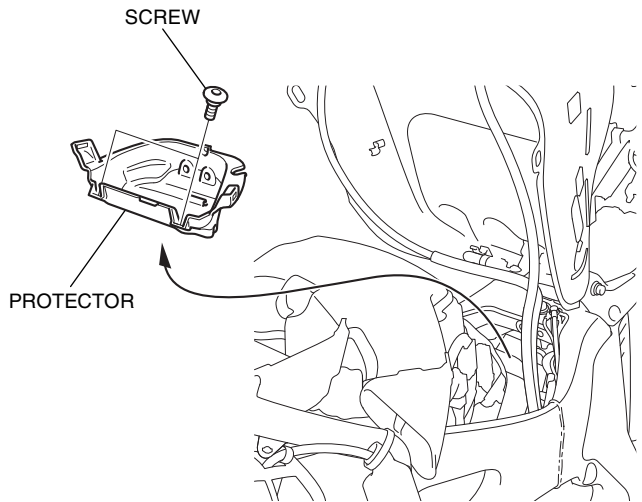

15. Route the socket harness as shown.

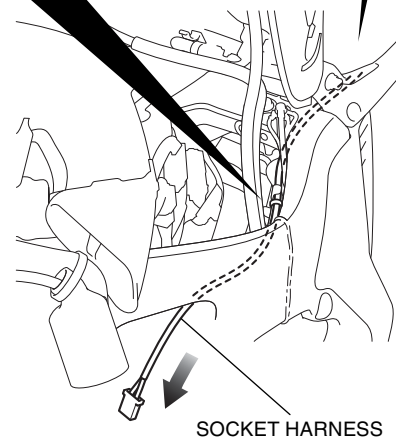
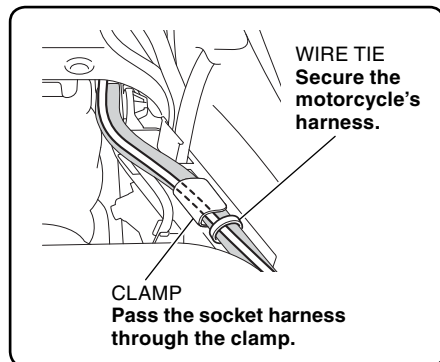

16. Route and secure the socket harness with the wire tie as shown.

<VFR1200X>

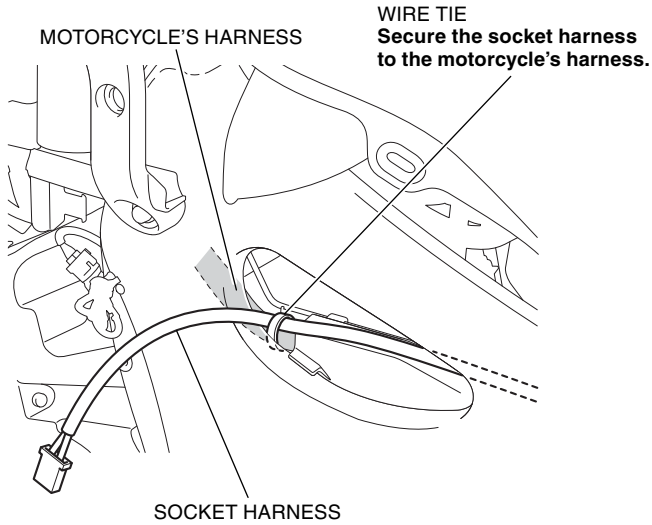

<VFR1200XD>

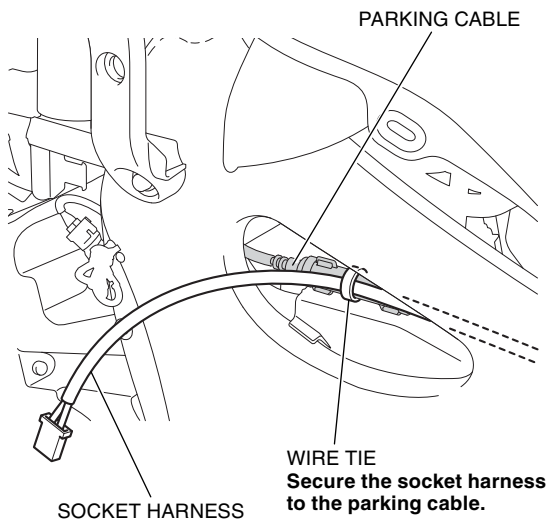

17. Connect the socket harness as shown.

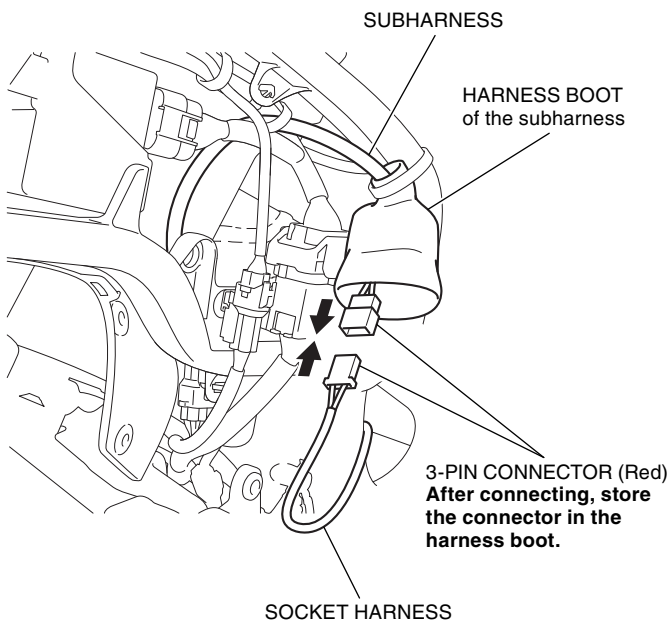

18. Secure the socket harness with the wire tie as shown.

- Do not cut the excess wire tie ends.

WIRE TIE
(Included in the subharness)
Secure the subharness to the cowl stay.

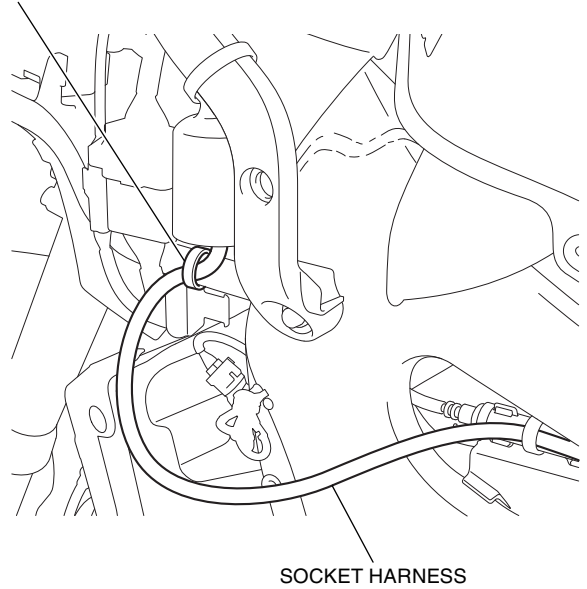

19. Bundle the socket harness with the wire tie as shown.

WIRE TIE
Bundle the excess harness.

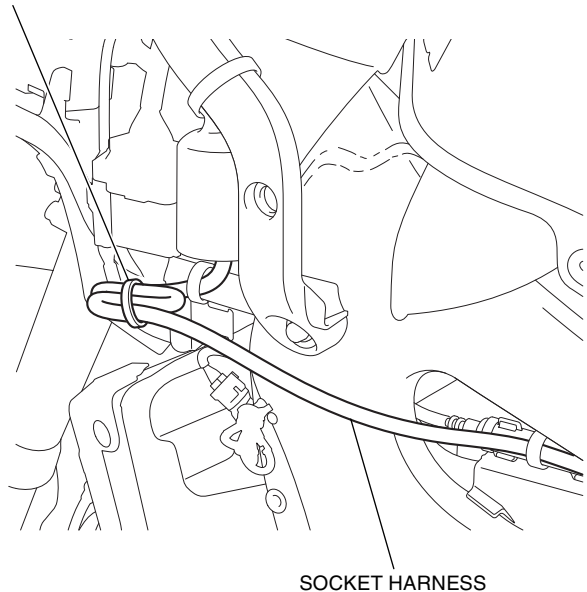

20. Install the motorcycle's parts in the reverse order of removal.

- Confirm that any harness is not caught or too tight.

21. Move the handlebar right and left and check that this accessory does not interfere with the motorcycle's normal operation.